

#1 Understanding Feminism

Elder Tess Lambert 10.24.2021

Eden 2 Eden Camp Meeting – Make the Right Choice

<https://www.youtube.com/watch?v=dGjmNwdpOKQ>

Opening Prayer

Hello everyone. We'll start with a prayer, if you'll kneel with me.

Dear Lord, thank you for our blessings. Thank you that at such different times we can meet. May we be impressed again with the seriousness of the time we live in. I pray that you'll grant us understanding, that we will know who you need us to be in this time period, that we will see your image and be changed. I pray this in Jesus' name. Amen.

Introduction

Last camp meeting we were meaning to speak about China and that didn't really happen. So, I said I would speak about China's role in prophecy at the next camp meeting; that is looking less likely. We keep getting sidetracked, but I think that is because there are things that are very important to discuss still all related to building on the midnight cry message; in the seriousness of the time that we live in requires us to really understand it. So, I intend at the next camp meeting to address the counterfeit first, and then if there is time, we'll discuss China. And then there was a third topic I want to discuss and I thought if I do it in a standalone presentation today, that will free up the camp meeting; and now last night I realized we would not finish it today. I could try, but I would have messages from translators afterwards. So, it may take the first part of the next camp meeting to continue.

Over the last 18 months some of the things that stick most strongly in my mind are not just presentations, but discussions that I have had. Some of the most powerful things of the last 18 months have been in private discussions (not limited to but mostly with women), discussing the midnight cry message, equality and feminism, how it impacts their lives, and the controversial elements of feminism. At the end of these discussions, I've often felt regret that they are private, because I have been blessed by them; the truth has shown brighter, but it's a private experience. And I often wished that some of those conversations were public discourse. I think the movement is left behind on some of these topics. I can be quite limited; people know that I'm slow to respond. So, there's a human inefficiency to one-on-one conversations, that also makes it difficult to discuss these things privately. Most of these discussions center around the subject of feminism and how pervasive inequality really is. I had a conversation over the last few months (because we go very slowly) with a woman in the movement sharing our thoughts on feminism, the sexism within gender stereotypes, and how that then relates to trans women; and in researching and discussing with her, I thought these are thoughts that should be shared publicly, urgently, because as a Movement we should understand feminism.

[It's been] three years since the midnight cry [2018], two years since the 'Increase of Knowledge' of the 'Sunday Law,' and I realized how many do not understand feminism, especially in a dispensation where we have gone from simple (two years ago) to the complex. It's not enough to tick off a box to go from Republican to Democrat. I think when we first taught in 2019 many people said they've moved from Republican to Democrat, because they are good in the heart Republicans; and a good Republican understands individual freedom. So, when we came with a message that seems to teach individual freedom, Republicans were attracted to the Republicanism they saw in that; but without understanding what it means to be a Democrat (and I'll use those terms figuratively), there's no heart change. Because we are over 18 months into an epidemic and where is your party of individual freedom? It's not enough to tick a box that says 'freedom' and not understand the difference between various versions of freedom; because the party of individual freedom, fighting against vaccine mandates, is Republicanism. In a similar way it's not enough to tick a box and say 'feminist' without understanding the various versions of feminism. Our relationship to freedom should be understood. Our relationship to feminism should be understood.

Broad Explanation of Feminism

I thought this would be a standalone study, because the main focus was on feminism and the trans community; but I think before that we need to give a broader explanation of feminism. So, it will take longer. There's one definition of sexism that I think is a good one. "Sexism is the name that feminists have used to explain how social inequalities between men and women are reinforced or upheld through norms, values, and attitudes."¹ So, norms, values, and attitudes uphold social inequalities between men and women that we describe as sexism. So, what needs to be challenged are norms, values, and attitudes.

Feminism is a very divided movement with various factions in opposition to the beliefs and ideals of other factions. I want to spend the majority of time discussing those factions, but I'm just going to mention a little history to build us towards that, which we will trace as a number of ways. There isn't even consensus on how many ways there are, if there's three or if there's four.

First Wave Feminism

The First Wave begins around 1848, the Seneca falls convention. There was two women who were active abolitionists. In 1840 there was a world anti-slavery convention in London. No women were allowed. These two women came anyway, and they were barred; that is where they met. Come to New York State [in] 1848, they've brought together about 200 women. They discussed their grievances; discussed the social, civil, and religious conditions and rights of women. They ended up passing 12 resolutions calling for specific equal rights, including (after much debate) the right to vote. So, I'm skipping through this history very quickly.

¹ Bigman, Fran. "What's Wrong with Popular Feminism?" *Los Angeles Review of Books*. April 19, 2019. <https://lareviewofbooks.org/article/whats-wrong-with-popular-feminism/>

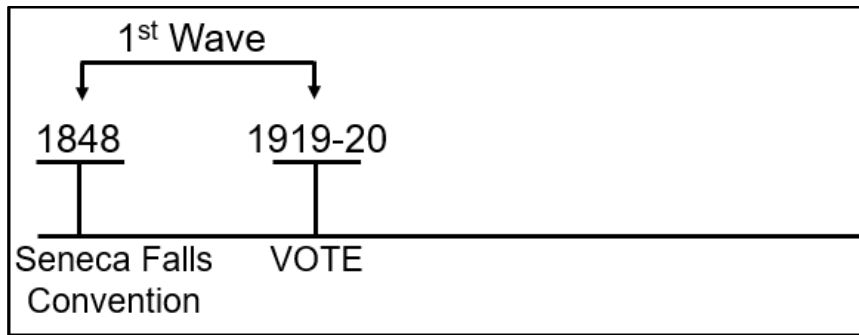

I'm going to go straight to 1919-1920; about 70 years later [after 1848], they're given the right to vote. In 1920 congress passed the 19th amendment granting women the right to vote. In theory it granted the right to women of all races, but in practice it remained difficult for black women to vote especially in the South. So, it's not an equal victory for all women, but it was a starting point. This is the main victory of First Wave Feminism. There's still a lot that's not equal; there's the financial sphere, the workplace, education, housing, home life. They can vote, but there's little of anything else. We know that there was World War I, World War II. Many women went into the workforce for the first time in World War II, and this empowered them. It showed them what they were capable of; they could do this work, and they enjoyed it. They had a glimpse of freedom. The war ends, men come home, and many women lose their jobs.

Second Wave Feminism

Second Wave Feminism begins around the early 1960s. It had really been swelling since the end of World War II. And a book is published in 1963; it's called *The Feminine Mystique*. It was written by Betty Friedan. And it sparked the beginning of Second Wave Feminism. This [the following quote] is just from the Wikipedia page on that book. "The phrase 'feminine mystique' was created by Friedan to describe the assumptions that women would be fulfilled from their housework, marriage, sexual lives, and children. It was said that women, who were actually feminine, should not have wanted to work, get an education, or have political opinions."² Friedan wanted to prove that women were unsatisfied and could not voice their feelings.

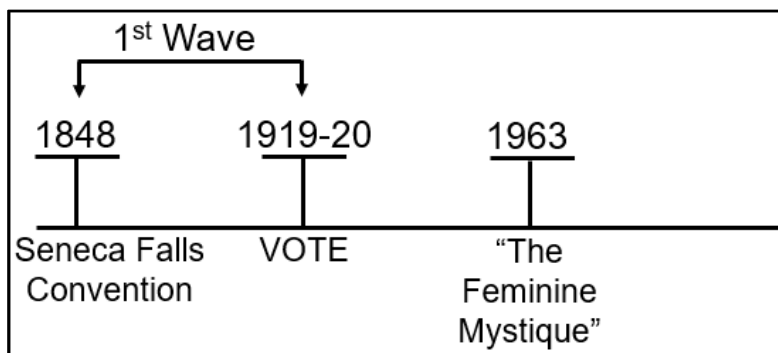

So, I want us to take a moment to think; many of you are talking about your generation, your parents' generation, or your grandparent's generation. I want us to consider how new 'rights for women' are. If we can hold into our minds (I would say permanently, but at least through these studies), **this is new**. Therefore,

² "The Feminine Mystique." *Wikipedia*. https://en.wikipedia.org/wiki/The_Feminine_Mystique

how is society today? How much has changed? How much is still considered normal? This was a revolutionary and controversial thought; that it was not anti-feminine for a woman to want to work, or have an education, or have a political opinion. We understand that that is revolutionary in the 1960s. We understand why Ellen White then was a progressive for her time, but also why she was limited in expressing political opinions. And we should especially consider our own time.

Second Wave Feminism saw a wave of legal victories. The 1964 Civil Rights Act included protections for women. “Ironically, protection for women had been included at the suggestion of a Virginia congressman in an attempt to prevent the act’s passage; his reasoning seemed to be that, while a white man might accept that African Americans needed and deserved protection from discrimination, the idea that women deserved equality with men would be far too radical for any of his male colleagues to contemplate.”³

These [the following] are the other legal victories of Second Wave Feminism. There was then a 1967 Executive Order [11375] extending full affirmative action rights to women. A 1968 decision ruled sex-segregated help wanted ads as illegal. So, if you wanted to employ someone you couldn't say, “men only apply.” Title 9 and the Women's Educational Equity Act. Title 10, Health and Family Planning. 1974 Equal Credit Opportunity Act, [which] said you couldn't be denied credit based on sex, race, or religion. Pregnancy Discrimination Act of 1978; you couldn't be fired if you became pregnant. The beginning of outlawing of marital rape, but it was still legal in some states through until 1993; which means they didn't consider it wrong or illegal for a man to rape his wife. The legalization of no fault of divorce made it easier for women in proving when relationships were unhealthy, although not legalized in all states until 2010. 1975 law requiring the US Military academies to admit women. And [there were] a number of Supreme Court cases; Roe vs. Wade is the famous one, but there was also Reed vs. Reed.

[In Reed vs. Reed] a couple had separated, their son had died, and by law in their estate when both a man and a woman are available to take control of an estate the court must give preference to the man as the administrator of the estate. So, the court had ruled that for the son, the father had to be the administrator of his estate, because male was to always have preference over a female. And the wife took that up to the Supreme Court. There was no money in it, but she was fighting against the principal, and she won.

So that's the fight in the 60s and 70s, and it was a war just to get those **basic equalities**. You come to 1989 and our reform line. There's no clear end to this Second Wave Feminism; **I'm going to mark 1989, but that is not really a position you'll find online**. They just generally say the late 1980s or the 1980s.

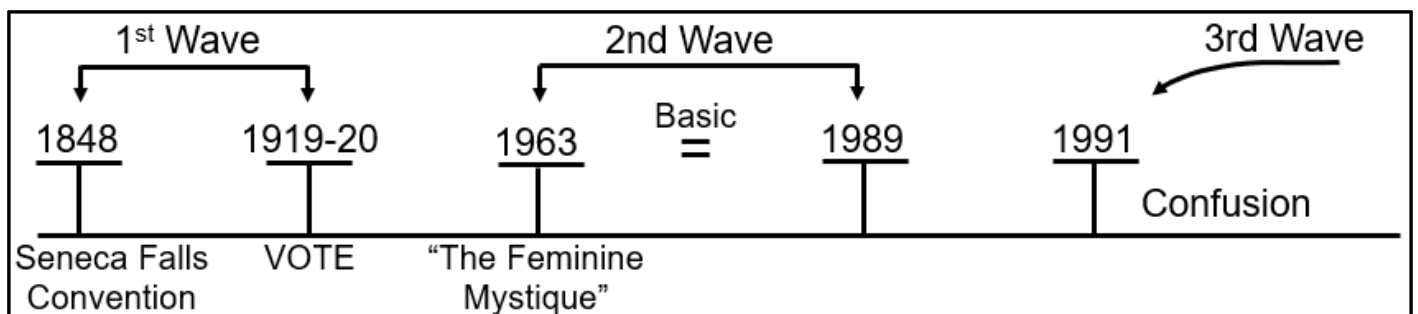

³ “Second-wave feminism.” Khan Academy. <https://www.khanacademy.org/humanities/us-history/postwarera/1960s-america/a/second-wave-feminism>

Third Wave Feminism

There's generally an acceptance that a Third Wave starts in 1991. And I would argue that since 1991 it's all confusion, splintering, disagreement; we'll discuss this. But a couple of things happened in 1989 that are worth mentioning. First of all is a proper introduction and understand of Intersectionality. "The term *intersectionality* [is used] to describe the idea that women experience 'layers of oppression' caused, for example, by gender, race and class. It was introduced by Kimberly Williams Crenshaw in 1989, and it was during the Third Wave that the concept flourished."⁴ So, it's continued to grow in public discourse discussion since then. The second important turning point in 1989 was another Supreme Court case 'Price Waterhouse v. Hopkins.' We won't discuss that now; we'll come back to it.

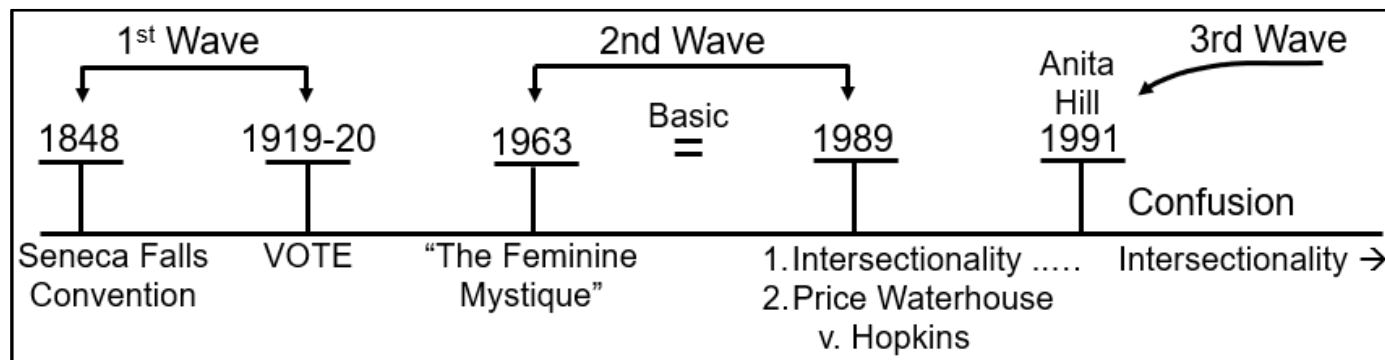

1991 was also about the Supreme Court (but in a different way) with the nomination of Clarence Thomas to the Supreme Court and a woman he had sexually abused, Anita Hill, spoke up. He was accepted to the Supreme Court anyway. The term 'Third Wave' is credited to Rebecca Walker who responded to Thomas's appointment to the Supreme Court with an article in *MS Magazine* "Becoming the Third Wave." She wrote, "So I write this as a plea to all women, especially women of my generation: Let Thomas' confirmation serve to remind you, as it did me, that the fight is far from over. Let this dismissal of a woman's experience move you to anger. Turn that outrage into political power." "I am not a post-feminism feminist. I am the Third Wave."⁵

Feminism has always been split from the very beginning, but post 1991 it became much more so, visibly. And I would suggest one of the reasons those splits within feminism are more visible now is because the First and Second Wave were clearly fighting law. Once you have Anita Hill's testimony ignored, **now you're fighting society's mindset**. So, the goals of feminism become harder to define, the disagreements between sections of feminism become even more pronounced, and the victories of feminism become much more difficult to identify. Because law is one thing, culture and mindset is another.

I wanted to move from a discussion of just history, to discussing the three main splits within feminism: **Cultural Feminism**, **Liberal Feminism** (also described as Mainstream Feminism), and **Radical Feminism**. Before we get into these three divisions, we'll take a moment and we're going to step back into the First Wave.

⁴ Third-wave feminism. *Wikipedia*. https://en.wikipedia.org/wiki/Third-wave_feminism#cite_note-FOOTNOTEEvans201519-12

⁵ *Ibid*.



Women want the right to vote. What are the attacks made on them? What's the response of society? I want to screen share some editorials from that time period. This one ['Meeting of Cabinet Ministers 1978'] is decades before; this isn't 1978, this is pre-1920. And they are joking about what a meeting of cabinet ministers will look like in that far-off date of 1978. Women gossiping around cups of tea. And I want you to start taking note of what the women look like. What do the women look like?



Number two. 'Origin and Development of a Suffragette.' At 15 a little pet. At 20 a little coquette. At 40 not married yet. At 50 a suffragette. And what happens to her appearance again? So, at 20 she's a coquette; to be a coquette it means to be a woman who tries to get the attention of men, flirtatious, but without affection. So, it's not being flirty in an affectionate or playful way; it's a boldness. At 40 she couldn't find a husband yet; no man would have her. Again, her appearance.



Another from the time. Down with man! Husbands for old maids! Holding up a rolled-up pamphlet saying, "Votes for women." What do you note about the physical appearance?

This was how society responded to the suffragettes: ugly, unlovable, unmarried, worst of all, unattractive.



“This is the house that man built. And these are a few of the women of note who say that they want, and they will have the vote; and think that they ought, to have man support: even although he should have to go short, the sly suffragette who is all on the get and wants all, in the house that man built.”

This is why I don't like people referring to men and women as man. I won't get into that argument now. Again, is the issue of appearance. And I consider that they're introducing racial overtones, when they change her skin color.

“What I want to do with feminists. What I would do with the suffragists. We want the vote. Nobody loves me - guess I'll be a suffragette.”



And why are they unlovable? Because they are old, but worse they are unattractive. That was the key tool used to tarnish the reputation of suffragettes. The beautiful, innocent housewife; now they're painting suffragettes, not just as unattractive (outside the home sphere), but also the connotations of a street corner.



Okay, in case you thought this was restricted to the United States, here you have Switzerland. This [on the left] was the general response to the suffragette movement, and it was based on their physical appearance.

And this [on the right] is what they actually look like, normal women, who believed in a right to vote.



For those that were arrested, this was an indication of part of the treatment. They discontinued force feeding through the mouth or nose once they were finally told that it caused long-term physical and psychological damage.

Look up Black Friday in Wikipedia, in London, black Friday, 1910. The physical and sexual attacks on 300 women protesting by both police and civilians; it continued for about six hours. So, they fought, and what was the response of society? The knife that society wanted to twist, heavily revolved around their appearance. By framing them as physically unattractive, they saw an opening they hoped would silence the movement. We're going to pick this up again in a moment.

Cultural Feminism

I want to address Cultural Feminism, then we'll come back to that same thing. I saw a really interesting article a couple of weeks ago, in *Foreign Policy*, called "Why Can't Women End Wars?" [Quote from the article:] "We're all aware of the gender imbalance in Silicon Valley and Hollywood. But the life-and-death imbalance is in peacemaking. In 2018, the World Economic Forum concluded: 'Only 4% of signatories to peace agreements between 1992 and 2011 were women, and only 9% of negotiators. And yet, studies have shown that female participation is the secret to ensuring lasting peace.'"⁶ So, when it comes to global conflict (even after First and Second Wave Feminism), war is an almost entirely male domain, not just in the hand-to-hand combat, but in all the decisions surrounding conflict and peace. Four percent of signatories are women and nine percent of negotiators are women. "According to U.N. Women, when women participate in a peace process, it increases the likelihood of peace lasting more than two years by 20 percent."⁷ I ended up not sharing this article because there was part of it [that] I didn't like, and that was that I could see through the article, they were arguing from the position of a Cultural Feminist.

Cultural Feminists, it's not about different nations, it's about male culture and female culture. "Cultural Feminism is a variety of feminism which emphasizes essential differences between men and women based on biological differences in reproductive capacity. In some cases, Cultural Feminism argues that a woman's way of looking at the world is actually superior to men's. The essence of being a woman is what makes women special and different compared to men, according to this view. This female essence includes a greater emphasis on cooperation, relationships and peace, also referred to as an ethic of care. Cultural feminists can either believe that being more nurturing is biologically determined, or they might believe that this trait was taught to them by society, or some combination of both." So, subtly in this article what I could see presented was that the reason women need to be involved in the peace process is because of the feminine "essence;" women are more cooperative, they are more kind, they nurture, they place more emphasis on relationships, it's the "ethics of care."

Now I would argue, why women are more successful at the peace process is because of cultural conditioning, which means women usually walk in with a smaller ego to defend, not because they are natural carers.

Cultural Feminism	Liberal (Mainstream) Feminism	Radical Feminism
Feminine "essence" Differences Men/Women ↓ Cooperative Kind Nurture Relationships "Ethics of Care"		

⁶ Di Geovanni, Janine. "Why Can't Women End Wars?" *Foreign Policy*. October 10, 2021. <https://foreignpolicy.com/2021/10/10/women-war-peace-security-wps/>

⁷ Ibid.

Cultural Feminists call for equal value, that the female essence of care must be treated with equal value to male essence of aggression, equal value for female occupations including parenting, even arguing for women to be paid for raising their children, because they still see that as a gendered role. While subtle in the article, it was still present; that's why it wasn't shared.

Pope Francis

The last time we spoke thoroughly about Pope Francis, we discussed his feminism; and it was this [Cultural Feminism]. Why does Pope Francis want more women giving input into the Catholic Church? For time, I'm not going to read all of his quotes; it's quite unpleasant, especially the way he talks about women who don't have children or women past child-bearing age. He describes the troubled condition of the Catholic Church as the condition of a woman who can no longer have children, like it's shriveled up, lost, no purpose. And even talks to nuns this way; "you've chosen not to have children." That they have to make sure they don't lose this [feminine "essence"], just because they don't have children. This is the feminism of Pope Francis, a church that worships the feminine essence of the Virgin Mary.

Cultural Feminism	Liberal (Mainstream) Feminism	Radical Feminism
Feminine "essence" Differences Men/Women ↓ Cooperative Kind Nurture Relationships "Ethics of Care" 		

Cultural Feminism developed from Radical Feminism, but they disagree when it comes to this [the differences of men/women]. Because what Cultural Feminism embraces, Radical Feminism seeks to undo. And what was interesting about that article (which was subtly but still from this [Cultural Feminism] perspective) (it's written by a woman by the way), is what do you do then with the women who aren't like this? It's like they would discuss how there would be more peace if there were women [involved], because women bring peace, because they have all the "ethics of care." But if this is innately in a woman, they stumbled awkwardly around women like Margaret Thatcher. Those parts of the article were not well written, because they had difficulty addressing all the women who have taken countries to war, not brought peace, and this idea where they make "ethics of care" a feminine trait. What about all the women that don't fit? What do you do with those people who don't conform to that gender stereotype? So, I'll leave Cultural Feminism there. I'll just say it's a faction of feminism we do not agree with. But for the proponents of it, it is very much feminism.

Liberal versus Radical Feminism

Then we come to liberal versus radical. We looked at the attacks made on First Wave feminists; it shows the high values society placed on a woman's value based on her physical appearance. Right back here [during the

First Wave]. So, if they wanted to attack, silence, First Wave feminists, Suffragettes, the route to their value was their physical appearance. So, you start to see a visible split within Second Wave Feminism, between Liberal (Mainstream) and Radical.

We'll go to 1968 and 1970. 1968 is the Miss America pageant; 1970 is Miss World. And Radical Feminists, they recognize what has been used to undermine them, and they turn out against these pageants. "The Miss America pageant has never been a progressive event, but in 1968, it sparked a feminist revolution. As women organized the first protest against Miss America, they were responding not only to the pageant and its antiquated, misogynistic attitudes toward women and beauty, but also to how the United States, as a whole, treated women.

The 1968 uprising was conceived by a radical feminist named Carol Hanisch, who popularized the phrase, 'The personal is political.'"⁸

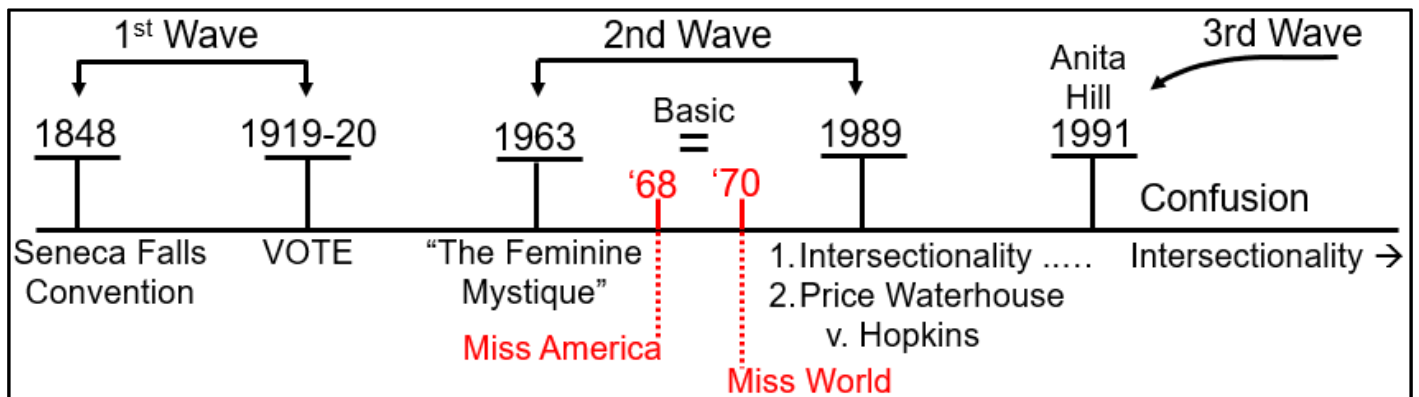

This is a key difference between Mainstream Liberal and Radical. [The] Liberal separates the personal, the home, from political activism, from political change. And the Radical Feminist says you cannot separate the personal decisions from the political implications. That has implications for home and personal decisions, but in this context it's beauty standards. "The protest would feature a 'freedom trash can' into which women could throw away all the physical manifestations of women's oppression, such as 'bras, girdles, curlers, false eyelashes, wigs, and representative issues of *Cosmopolitan*, *Ladies' Home Journal*, *Family Circle*, etc.'"⁹

Cultural Feminism	Liberal (Mainstream) Feminism	Radical Feminism
Feminine "essence" Differences Men/Women ↓ Cooperative Kind Nurture Relationships "Ethics of Care" Pope Francis		"The Personal is Political" Derogatory term → "Bra-burners"

⁸ Gay, Roxane. "1968: The Year That Shattered America." *Smithsonian Magazine*. January 2018.

<https://www.smithsonianmag.com/history/fifty-years-ago-protestors-took-on-miss-america-pageant-electrified-feminist-movement-180967504/>

⁹ Ibid.

You've heard of the derogatory term “Bra-burners;” it comes from this protest, where all feminism was then labeled with this idea that they’re “Bra-burners.” In fact, it was not Mainstream Feminism it was Radical Feminism, first mistake. And second this was not a protest of bras, basic underwear, but the beauty standards and sexualization of women; which was why this was about curlers, false eyelashes, wigs, makeup. They threw makeup into that pile as much as bras, and women's tabloid magazines. They are worse today than I think they were then. And girdles, which is really their modern form of a corset; it's shapewear designed to physically force the female body into an unnatural shape.

At this protest, “A prominent black feminist activist and lawyer, Florynce Kennedy, who went by Flo, chained herself to a puppet of Miss America ‘to highlight the ways women were enslaved by beauty standards.’”¹⁰

The second mistake where this protest is mischaracterized, it was never set on fire; it was thrown into the trash and is never burnt. “The myth can be traced back to the *New York Post* reporter Lindsay Van Gelder, who, in a piece before the protest, suggested protesters would burn bras, a nod to the burning of draft cards. After other *Post* writers reported the idea as fact, syndicated humor columnist Art Buchwald spread the myth nationwide.”¹¹

Remember First Wave feminists: radical, unattractive, unhinged. Radical Second Wave Feminist.

Continuing to quote Art Buckwalt, the journalist, “‘The final and most tragic part of the protest,’ he wrote, ‘took place when several of the women publicly burned their brassieres.’ He continued to revel in his misogyny, writing, ‘If the average American female gave up all her beauty products she would look like Tiny Tim and there would be no reason for the American male to have anything to do with her at all.’”¹² Suffragettes were mischaracterized; these Second Wave feminists were wildly mischaracterized. “In a handful of sentences, Buchwald neatly illustrated the urgent need for the protest.”¹³ Because it illustrated the mindset of the society when confronted with a segment of women who do not cave to the expectations of beauty standards.

1970 Miss World. “‘I am very, very happy to be here at this cattle market tonight,’ Bob Hope tells a packed-out Royal Albert Hall. ‘Moo. It’s quite a cattle market, I’ve been back there checking calves.’ The hall swells with laughter until a cracking sound from somewhere in the gallery cuts through, stopping Hope mid-gag. He peers out at the stalls, looks up at the balconies and the boxes. Crack, crack, crack – louder now – the sound ricocheting around the grand auditorium. A small white object flies through the air and lands, bursting into a puff of white on the stage floor. Another follows, and then another, and Hope is under fire from an assault of flour bombs. Missiles of rotten fruit and vegetables come next, pelted from the gallery. The 67-year-old dives for cover as a group of women begin to shout: ‘We’re not ugly! We’re not beautiful! We’re angry!’”¹⁴

¹⁰ Ibid.

¹¹ Ibid.

¹² Ibid.

¹³ Ibid.

¹⁴ Hall, Harriet. “‘We’re not ugly! We’re not beautiful! We’re angry!’ The feminists who flour bombed the 1970 Miss World pageant. *Independent*. Nov 27, 2020. <https://www.scribd.com/article/486600293/We-re-Not-Ugly-We-re-Not-Beautiful-We-re-Angry-The-Feminists-Who-Flour-Bombed-The-1970-Miss-World-Pageant>

It's 20 November 1970 and the flour bombers have infiltrated the Miss World finale where 58 female contestants wait in the wings to be paraded and broadcast live on the BBC. Like the *Bake Off* final, it's a national institution, the television event of the year. Over 100 million people worldwide have tuned in to see who will take home the crown. The broadcaster pulls transmission as the event descends into chaos. The protesters are escorted out by police."¹⁵

The first couple of times I read this story I laughed so much; the description of it is so comical. But I don't think we realize the extent of the horror. I think people do, to a higher degree, when it comes to race. When you are objectified, animalized, and society rates you on value by appearance. And I think their chant is profound. They didn't chant we're all beautiful. They didn't chant body positivity. They chanted, 'body does not matter.' We're not ugly, we're not beautiful, we're angry. They didn't intend to actually start flower bombing until later in the pageant, but by the time Bob Hope gets to these latest statements, they are too angry. And remember that for all those women sitting there angry, they're surrounded by women dressed luxuriously, enjoying the show, and a backstage full of women happy to be calves. And the first Miss World pageant won by a black woman, which gave them the ability to describe the Miss World pageant as progressive. This is why feminism is split. We know Cultural Feminism is a problem, but we need to trace the history, and divide between Mainstream and Radical, and how that impacts us as a Movement.

We're not even halfway through our material, but we'll continue at the Camp Meeting. But I'll ask you this, if this difference in feminism doesn't matter, do you really think it's a coincidence that Donald Trump, the human face of the Sunday Law, was famous before becoming president for owning the Miss Universe pageant? It was his ownership of pageants that garnered so much attention. So, when we get into a history where it's complicated, where everyone cries freedom, and none so loudly as a Republican, we don't need to understand who's crying feminism. Remember if you take his word for it, there's no greater feminist than Donald Trump and his silent supermodel wife, and his pageants. We're still in the time period of the Apis Bull, so we need to understand feminism; how they relate to us as members of the Movement.

Closing Prayer

If you will kneel with me, we will close in prayer.

Dear Lord, we know that our objective is to honor you, glorify you, show your character, partly through a compare and contrast with what you are not. I pray that we'll understand you better, live more selflessly. As we cease our work as priests, consider our role as 144,000, may the narrow way not feel too narrow. When we see that you have good reasons for what is often more than good advice. We pray this in Jesus name. Amen.

¹⁵ Hall, Harriet. "'We're not ugly! We're not beautiful! We're angry!' The feminists who flour bombed the 1970 Miss World pageant. *Independent*. Nov 27, 2020. <https://www.scribd.com/article/486600293/We-re-Not-Ugly-We-re-Not-Beautiful-We-re-Angry-The-Feminists-Who-Flour-Bombed-The-1970-Miss-World-Pageant>