

An Unpopular Message

Elder Tess Lambert – April 10, 2021

<https://www.youtube.com/watch?v=KRnWEnFKSB0>

Boardwork from 'The Test that Shipwrecks Two Institutions' - Elder Tess – April 4, 2021

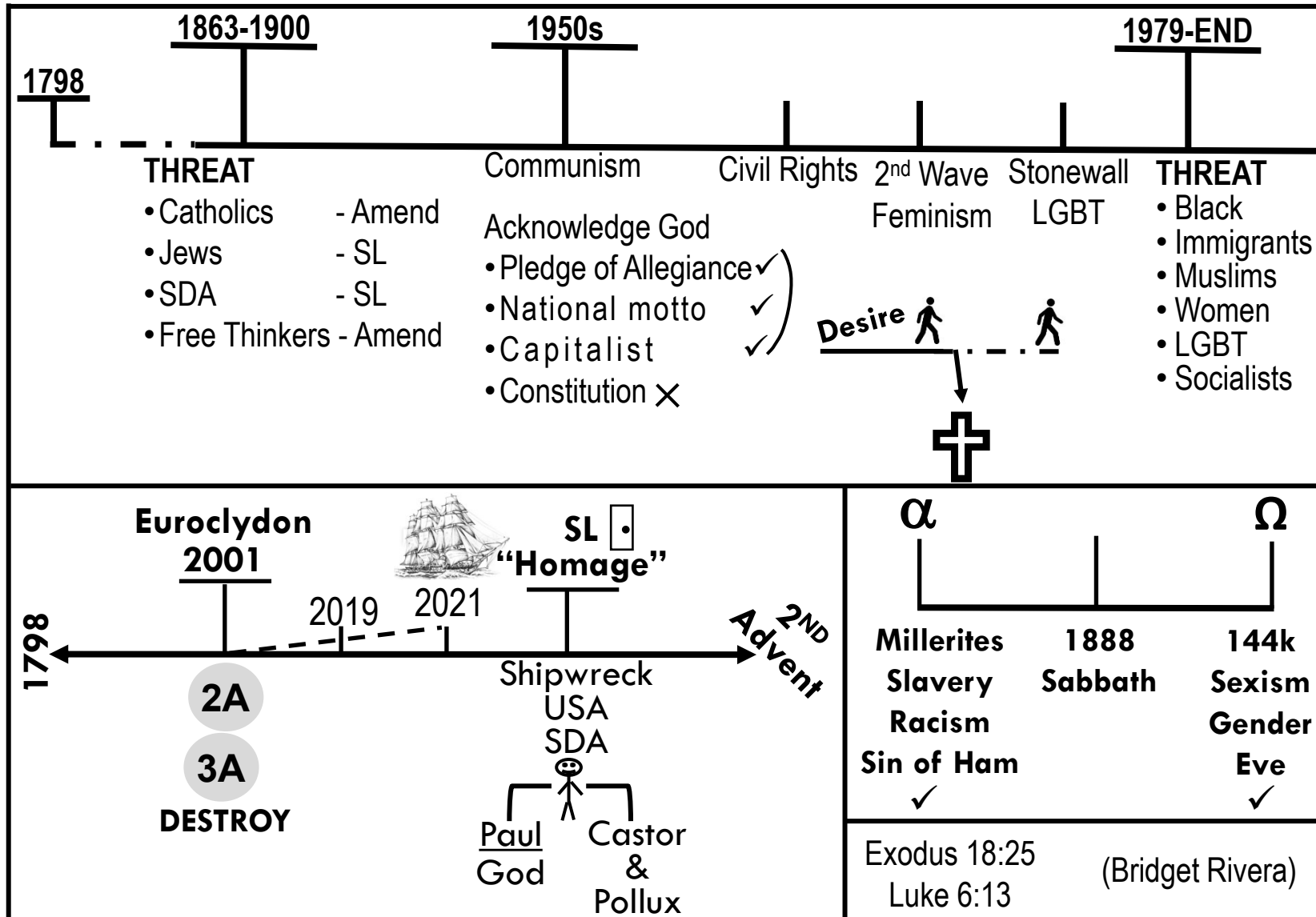

At last camp meeting [Guadeloupe April 2021] there were really four different topics I wanted to address; as always, they're very much linked.

I wanted to look at Acts 27 again, that second ship of Alexandria. It doesn't actually enter into our story until part way through its voyage, when the ship finally interacts with Paul. But we begin its journey in Alexandria, therefore we begin our story, our line there, because it's the ship that we are tracing. That's the theme of our story.

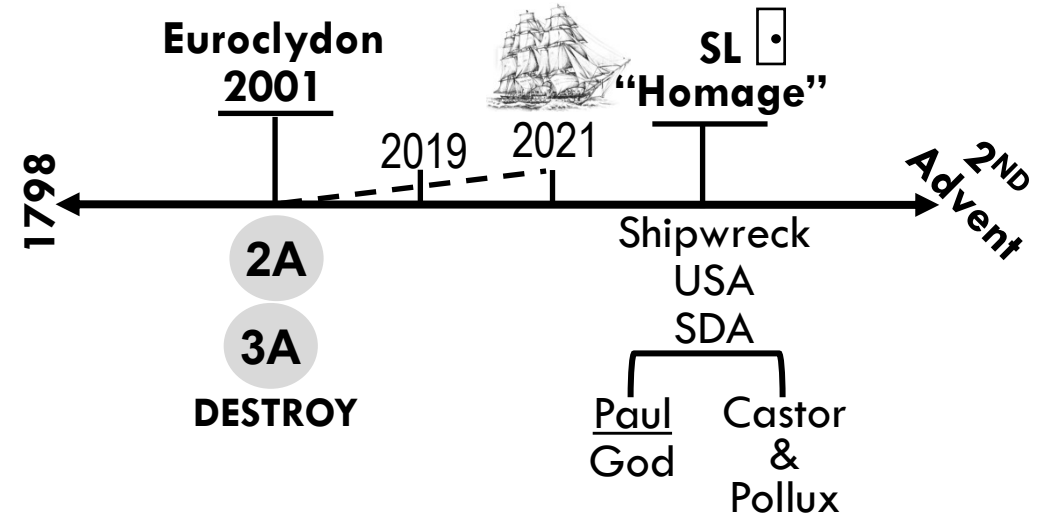

It isn't about what interaction it had with Paul; the theme is the ship. So, knowing where it came from, we go back into its history and begin our story there. And keeping in mind that the theme is not Paul, we have to then consider where that ship was meant to go. Paul may have been destined for Rome, but the ship was not. Paul doesn't begin in Alexandria, the ship does. Paul's journey was not meant to end in Puteoli, but the ship was. So, it begins in Alexandria; it ends in Puteoli. Paul's journey both begins and ends somewhere else. So, it's wrong to try and end that line with Rome; it doesn't end with Rome, it ends with Puteoli. So, I wanted to have a discussion on that line, just to tidy up our end.

Then I wanted to go back to our document, *How the Constitution Became Christian*, and look again at those three histories of Protestantism.

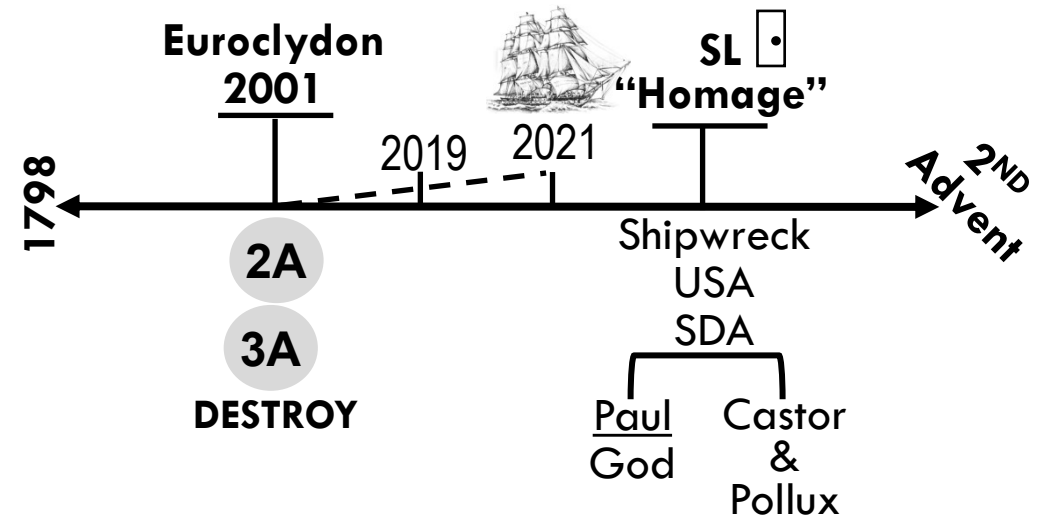

I wanted to look at Acts 27, then wanted to go back to our document. And we could say that those two different subjects are all about the same thing; because we went to Acts 27, considered the two institutions, saw they're shipwrecked at the Sunday Law, we asked why, so we went back to our document. So, we linked those two studies with the waymark of shipwreck.

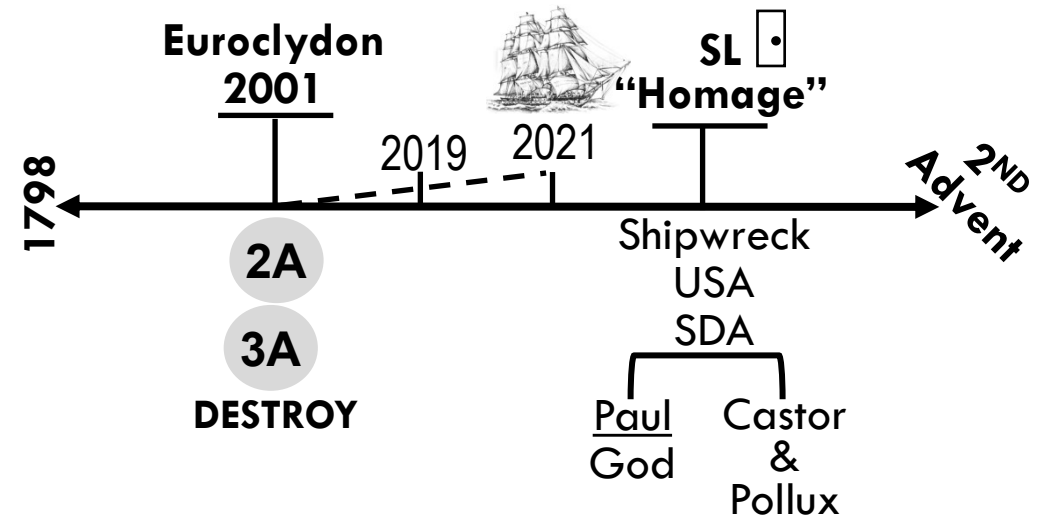

We completed the thoughts that I wanted to make from that document. We also used the book *The Evangelicals* to discuss especially the second history in more detail, and how Fundamentalism changed in its behavior and language. I wanted to show how in the early 20th century Fundamentalism changed. They were really beaten down through the early 1900s; so, they changed some of their language, such as Christian to Judaeo-Christian, Fundamentalist to Evangelical. And then they resurrected particularly under Billy Graham and President Eisenhower, Church and State.

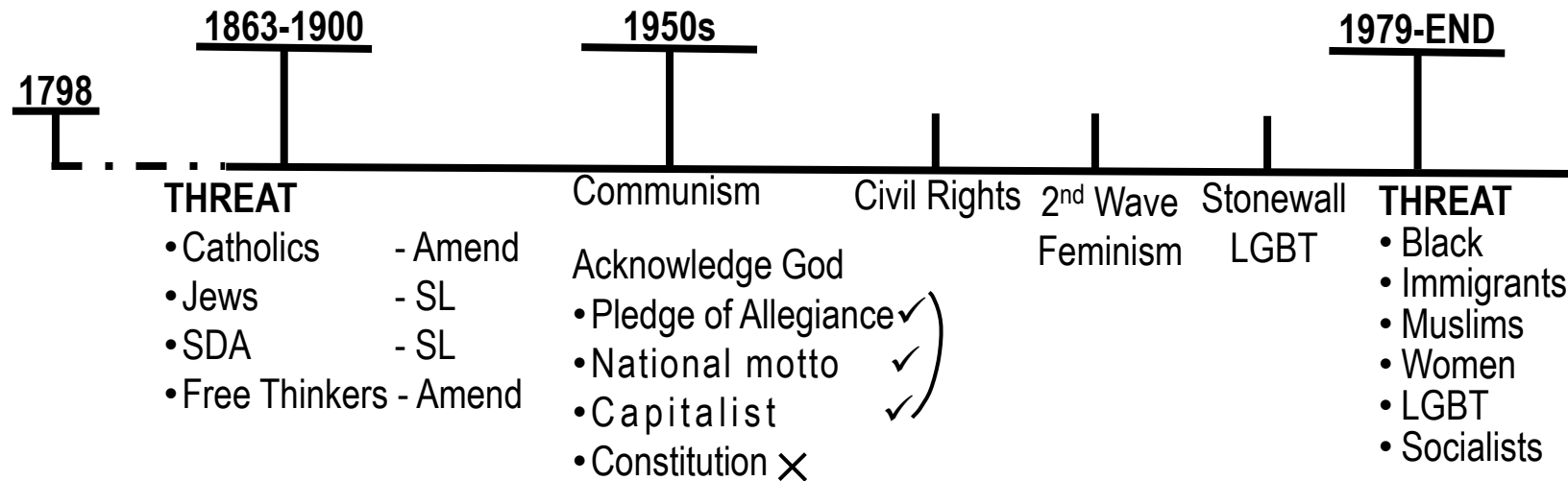

We spent time on the first 1888 history, especially as it came to Catholicism, which they hated; it was a threat. And how their response was especially targeted to take down the threat. Then if you wonder why a good evangelical loves capitalism so much, we came to our second threat, communism. And the response is targeted against the threat. And the problem is because Adventists don't understand dispensations. They're still standing here [with the threat], with the Great Controversy, thinking like an Adventist in 1888. But it gets much worse than that, because they're thinking like Adventists in 1888, but with a modern Evangelical brain. So, they take the Great Controversy and they meld it with their Evangelical brain; they forget all of the surrounding context and history of 1888, and they think that at the end of the world Catholics and Protestants are going to be friends; which is why so many Adventists today, even though their favorite book, the Great Controversy, tells them Protestantism is the threat, they cannot see it. The only threat they see is Francis, and they're waiting for some miracle to happen and Protestants to just start following Francis. It's incredibly blind prophetically.

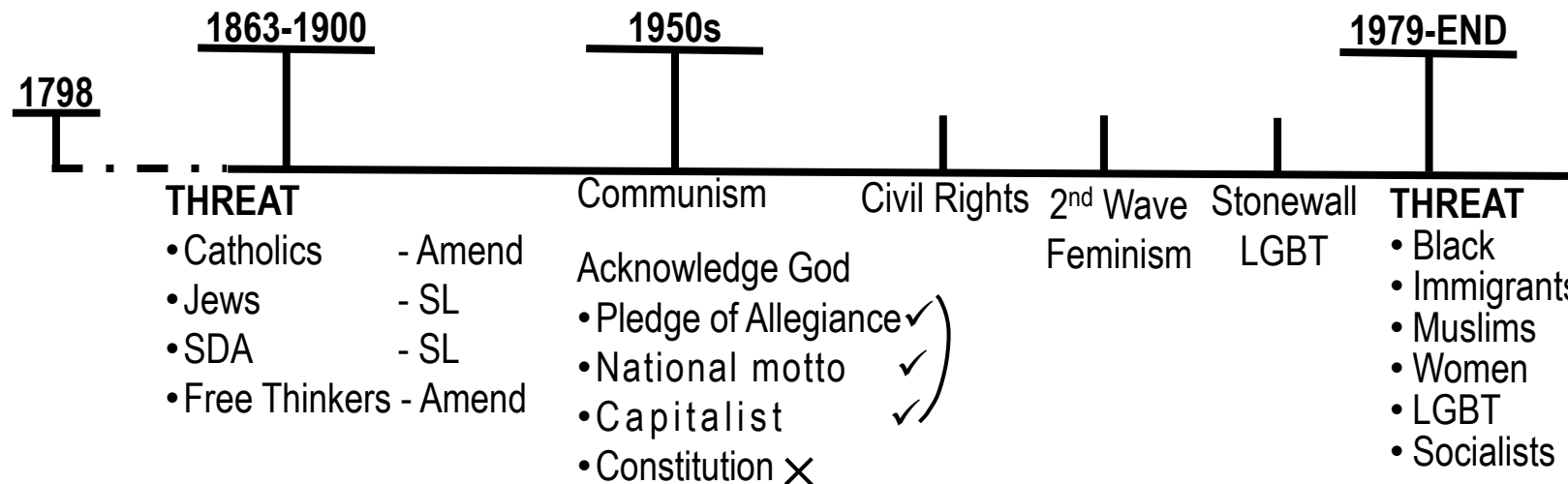

We looked at 1888 history, and 1950s history. Then we saw the rise of the third threat. It began with the Civil Rights movement, then under the Sexual Revolution was Second Wave Feminism, and then Stonewall. By 1979 there's a definable threat, and Fundamentalist Protestantism is ready to engage. And this third history is the last one; this will lead to the Sunday Law. So, we need to understand the threat, and how we stand in relation to it. We moved from there to discussing Adventist sources.

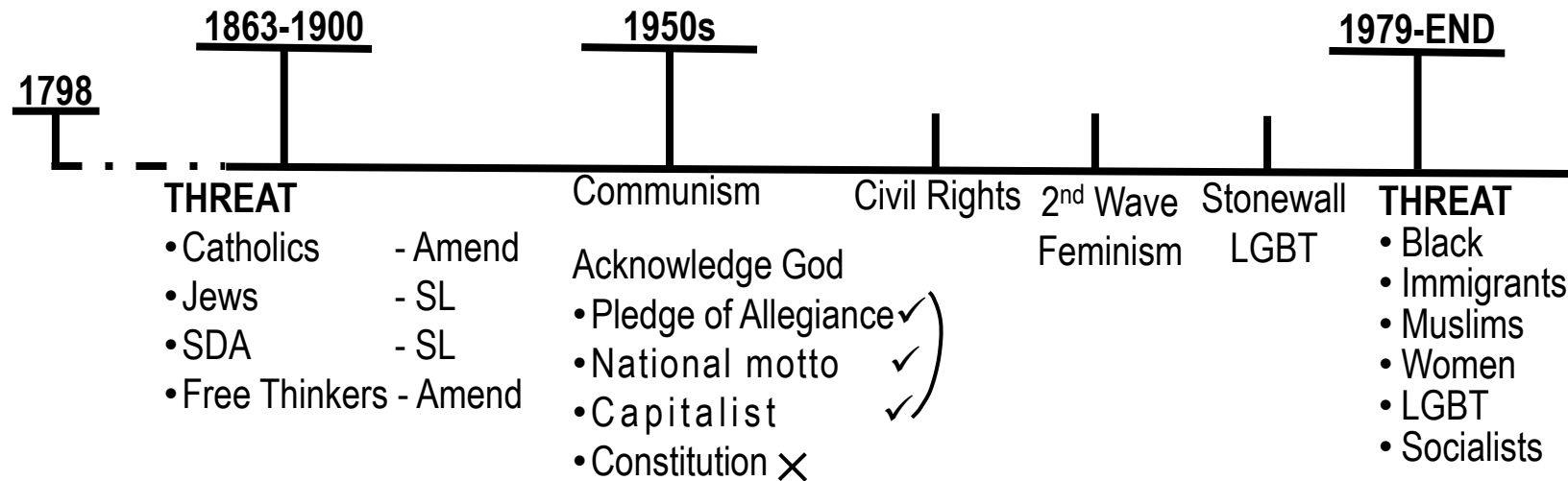

Of the Adventist sources, there were three that I wanted to speak about, that I know have been shared around this Movement. We only got to one of them, and that was Bridget Rivera. And my messages were not to try and shame her. Someone called her a false prophet; I don't want to see her that way. She's a victim in this story. But as much as we can learn to empathize with her experience, we have a problem when it comes to Adventist sources; because we think a liberal, who says a few nice words about equality, is necessarily less blind. And we can tend to look to them, not just to observe their own experience, but to think they really understand equality and we can learn from them. And I'm going to sound really arrogant, and say, no, we can't. Because what they're trying to bring is scriptural spiritual answers, and they don't have them. When we share other external sources, I'm not giving you the answer through inspiration; we are sharing the external context of that inspiration. But too often with Adventist sources, we're actually trying to do both.

An African author was also shared with me. He wrote a really nice article in spectrum about equality. So, I looked up into his other material. In his other material, I genuinely like the words he has to say about equality. But as an Adventist, hopefully Levite, I couldn't help but wonder why he never once seemed to mention the dowry system. Instead, what he's actually arguing for is the Africanization of Adventism. So, instead of discarding culture, he wants Adventism in Africa to be practiced with their cultural traditions. He starts to show what he means by this when he says that dancing has been regarded as unholy, but dancing is part of African culture. So, he may have nice words of equality, but when you actually look into his articles, he never challenges the deep-set patriarchal system of his own culture. He says, we have an obsession with 18th century hymns. This Movement requires us to put aside culture; put aside the patriarchal system in our culture. The dowry system needs to be put away; he never says that. In Western culture, why do we have fathers give away their daughters? No culture escapes this Movement. But he's not looking for a prophetic message. He's not looking to challenge his culture. And I would soon read Pope Francis as his nice words about equality, whether they're in spectrum or no. We don't have proper warning lights in place when we address liberal Adventism. That's all I want to review of that topic.

First, Acts 27; second, the document, *How the Constitution Became Christian*; third, Adventist sources; and fourth, Eden to Eden. Now we quite rushed that ending. We didn't get to discuss Eden to Eden as much as I had intended, yet I don't know if I have that much more to say about it. I find myself repeating a lot. The reason is every presentation I think it's clear; and then in the other six days of the week, I see the personal lives of people in this Movement. I start thinking it really mustn't be clear. So, I repeat it again, and then I repeat it again, and then I repeat it again, until I can start telling people, I'm speaking to you; and they still think I'm speaking to someone else.

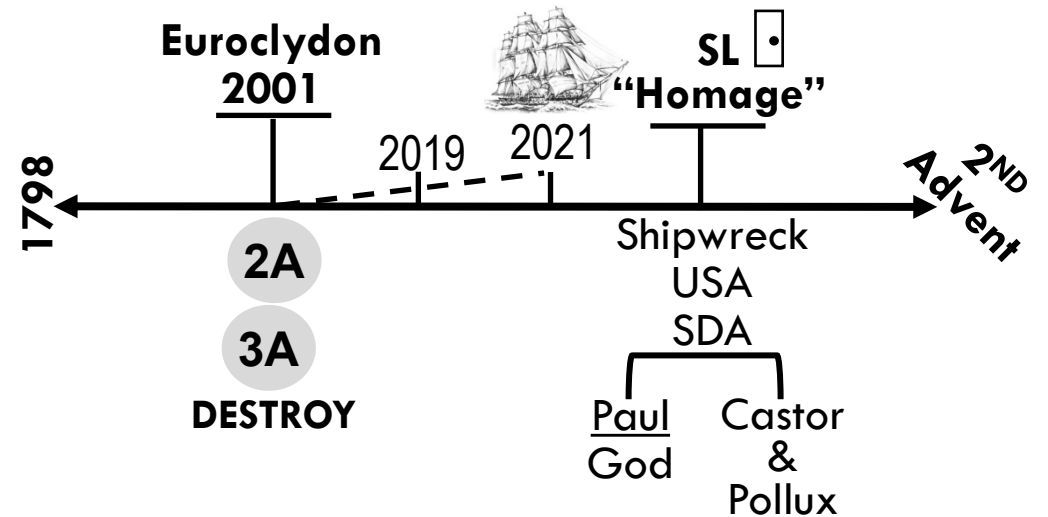

I wanted to make just a couple of thoughts about Eden to Eden.

What was the population of the United States in 1860? The population was 31,443,321; that was from the 1860 census.

By the beginning of the Civil War, how many people in the United States were involved in the abolitionist movement?



Population U.S. 1860 Census 31,443,321
--

Now question: If you were living in 1850, would you have been an Abolitionist, part of the Abolitionist movement?

I think every single one of us would say absolutely. We would have had strong feelings about it. I bet you think you would have been an abolitionist.

By the beginning of the Civil War, the number of people involved, who were just part of the movement, was 255,000, that's zero point something of a percent. One in 123 people would sign their name under abolition. And this number includes freed black people. These 255,000 are not all white people.

Population U.S. 1860 Census 31,443,321
Abolitionist By the Civil War beginning 255,000 That's 1 in 123.

Eden

Eden

So, do you think it likely that members of this Movement would have all been abolitionists back then? If we go by statistics, not one in a hundred. What we lose sight of, was how radical abolition was, how uncommon, how fanatical it was viewed. And we just phrase that test today as something so easy. Then remember that many of these Abolitionists, they only wanted abolition because they were starting to feel threatened by the black population, that over generations they might start to mix and that couldn't be tolerated. So, they needed to free those slaves, and send them all back to Africa to protect the white population. So, these 1 in 123 people are not all good people. Few people believed in actual equality; mental, physical, spiritual, equality. It was political suicide to say so in public. This 255,000 Abolitionists did not believe in equality. The vast majority of them still believed in a white America.

Why am I saying all this? We begin our story in Eden; we know that it ends in Eden.

Population U.S. 1860 Census 31,443,321
Abolitionist By the Civil War beginning 255,000 That's 1 in 123.

Eden

Eden



In our last Oceania Sabbath study [titled 'Three Steps of Restoration'], we discussed a return journey; that you could just take this [Eden to Eden line] and bend it; that we are returning to the place we came from. And if you're going to return to the place you came from, you're going to have to retrace your steps. You took step one, step two, step three; and then on the way back you take step three, step two, step one. As you leave, you may notice a rock, a tree, a flower. When you return, what's the order you will see them in? First, you will see your flower; then your tree, then your rock, and you're back to where you came from. That's a simple chiasm. So, God formed us in Eden; everything went wrong. God's working to restore us and bring us back to that condition. And what we said was, that it worked like a chiasm, like a return journey.

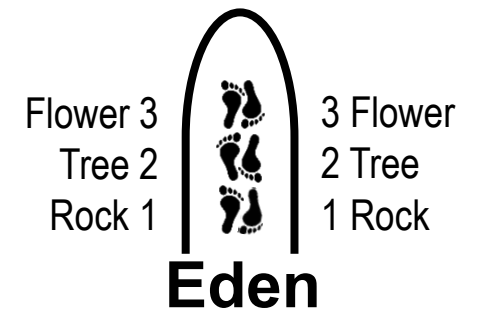

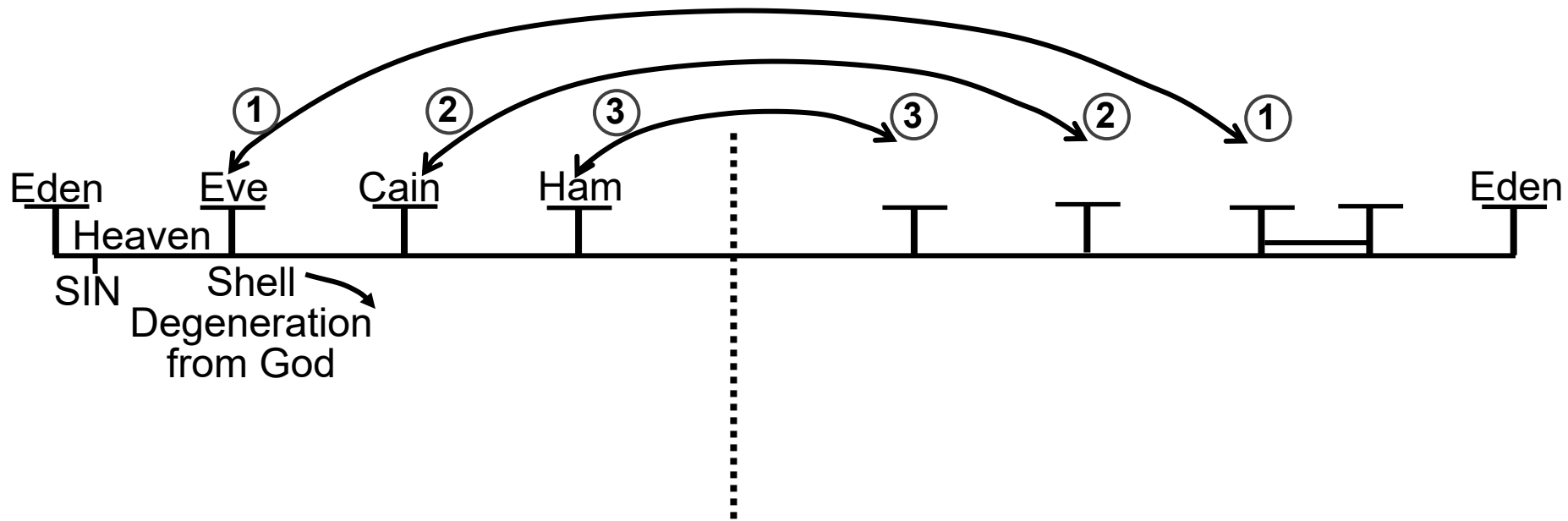

After Eden was formed, sin formed in Heaven, in the heart of Satan. It spills out onto this earth; and what's the first sin? Eve. The sin of Eve. When Eve and her husband sin, what happens to our shell? The shell begins to deteriorate. The first prominent sin was Eve, the second was Cain, and the third, marked in Genesis, was the sin of Ham. These sins brought particular consequences on the human race, consequences that are as much sin as the sin itself. And now God works to undo; beginning at the third, the second, and the first.

I've been getting very few questions from people, and I don't know if that's good or bad. For me it makes sense; I'm hoping for other people, they see it too.

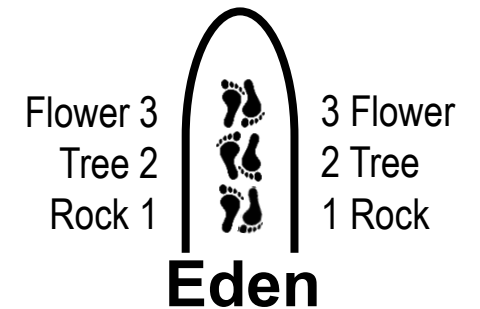

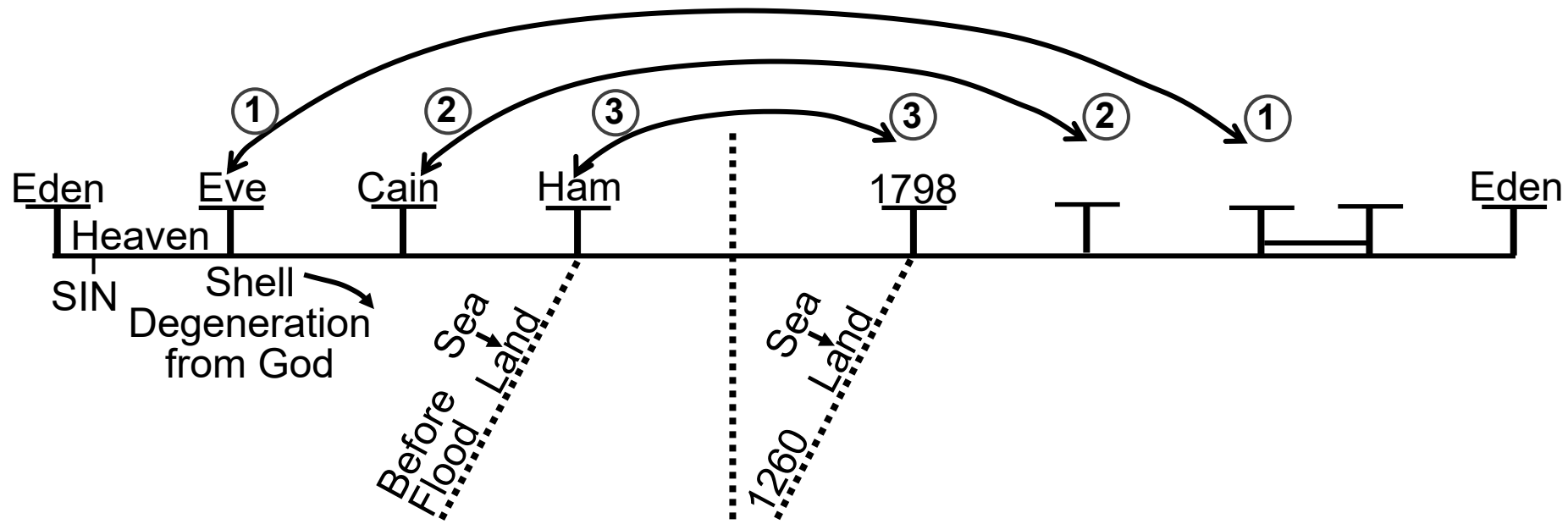

Prior to the sin of Ham, you had the world before the flood. So bad, God had to start again. God did that by taking people from the sea to the land; a new start on a dry barren land.

When do these steps of restoration begin? You have the 1260 years. If you want to know what the world looked like before the flood, look at the 1260. It wasn't rampant immorality the way people picture it. We have been making strong arguments for many months now that it was about abuse. So, God took people from the sea to the land [1260]. What chapter is that? Revelation 13. So, this restoration, this work of undoing, began in 1798. What did the sin of Ham cause?

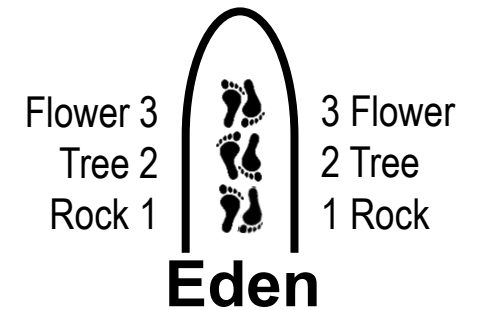

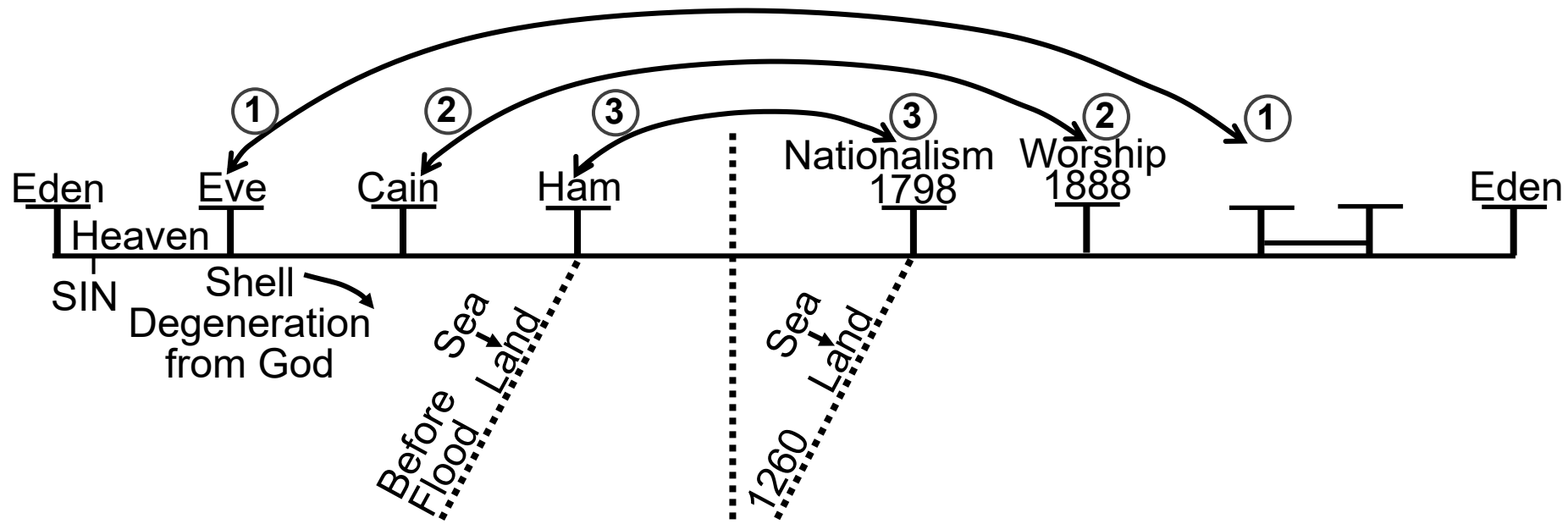

Nationalism, racism.

The next issue that we have to confront is Cain. This was all about worship. And we read a quote that spoke about the sin of Cain, and the result of his sin was the end of Sabbath keeping among him and his descendants. Patriarchs and Prophets 80.3. *“They chose their own time for labor and for rest, regardless of Jehovah’s express command.”*

Worship, Sabbath, 1888.

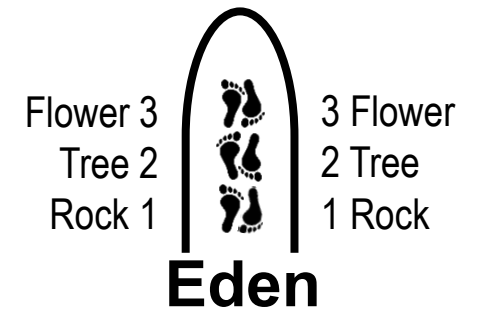

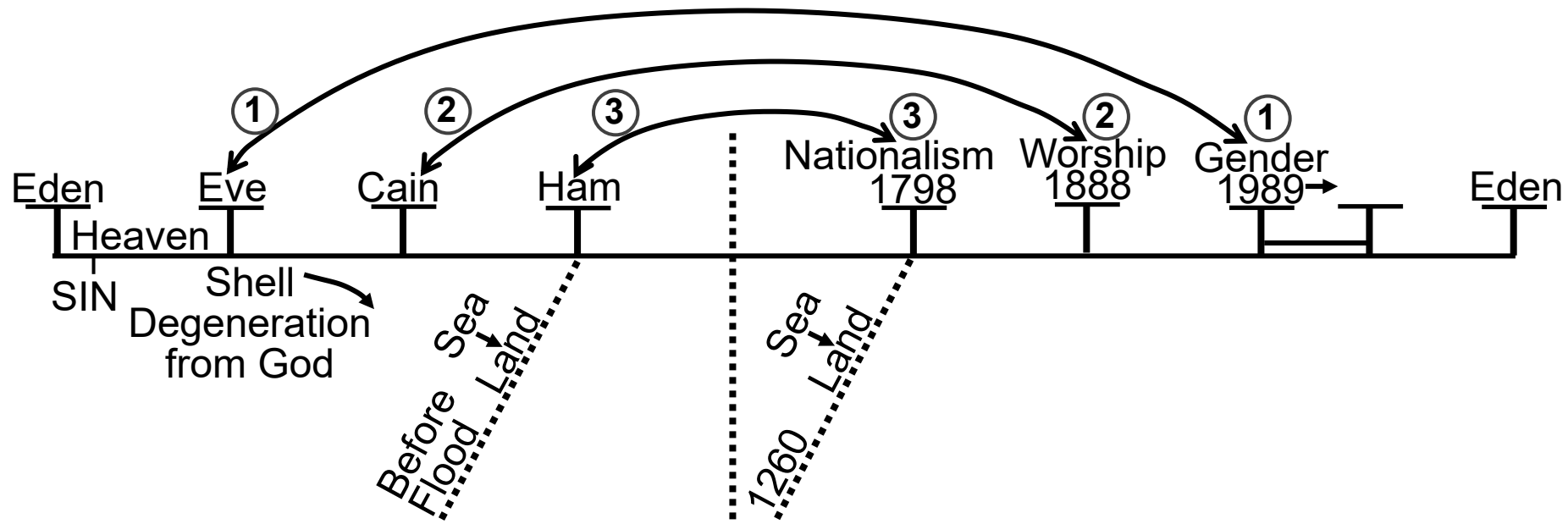

In our time, the line of the 144,000. We're dealing with, right back at the very beginning, the first sin. This is all about gender.

Now I think almost everyone joining today, has become comfortable with saying the Sabbath is not the Sunday Law test for us. This Sunday Law issue is not about Sunday. It's not this [Worship 1888]. If it's not this [Worship 1888], we should be pretty sure it's not this [Nationalism 1798]. I'm not always talking about the Sabbath [Worship 1888], so why am I always going back here [Nationalism 1798], talking about racism? It's not because I'm trying to say, you're all racists; because I'm not saying you're all Sabbath breakers. The issue is not Sabbath; it's also not race.

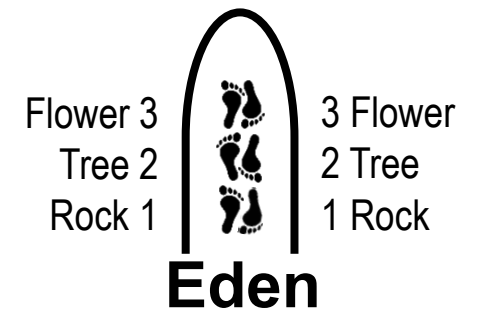

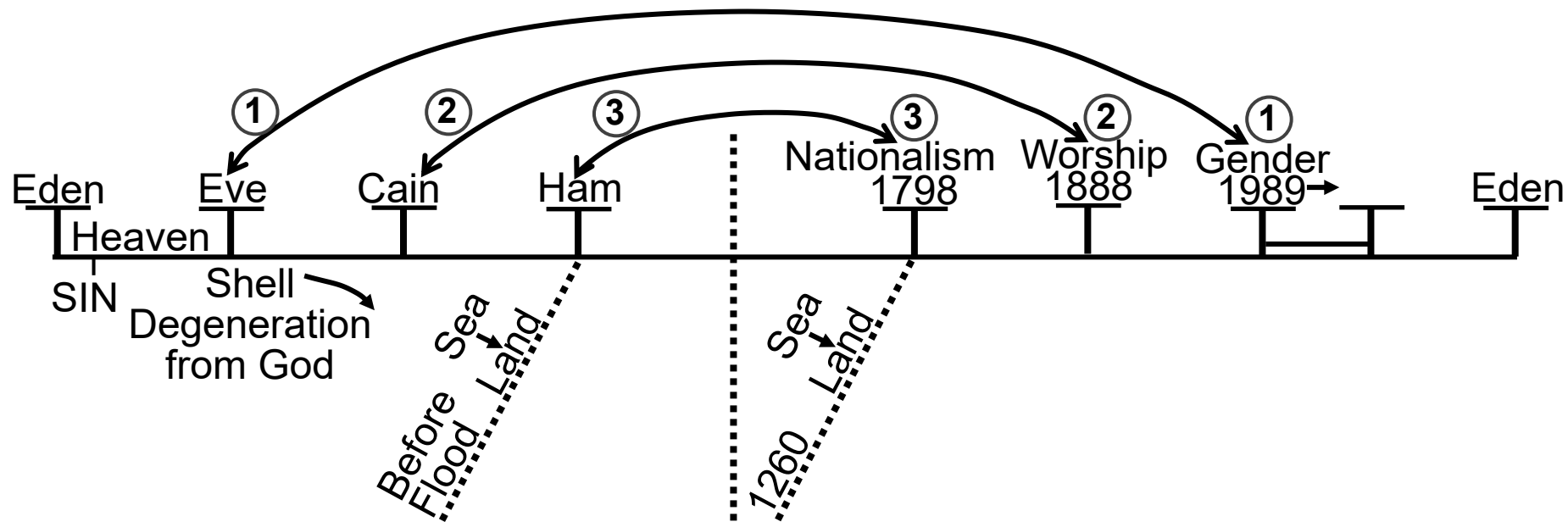

So, why did I go back to those statistics? I was never making a point about race. I was making a point about gender. Because if you think you would have stood for racial equality back here [Civil War] and you think you've done well with this gender test, I would disagree with you. It's a lot more radical, a lot more uncomfortable, than people are willing to recognize. If I was to stand up and say what I believe on gender equality, it would be political suicide for a Democrat. I'm not even talking about Republicans; I'm talking about Democrats. So, if we think the Democrats get equality, I guarantee you, if Biden had a daughter, he'd walk her down the aisle and he'd give her away. And all the Democrats would say that was beautiful.

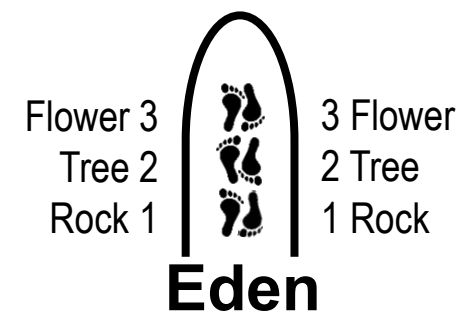

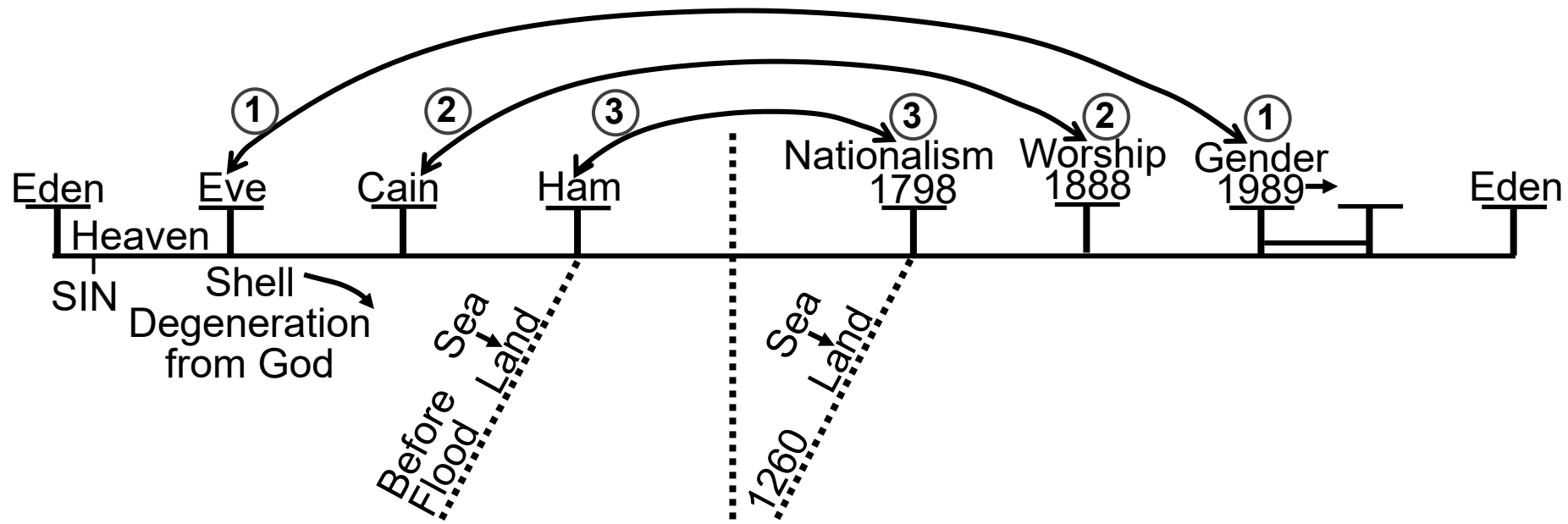

The position of a person who truly believed in racial equality was extreme. The United States is full of racists. Zimbabwe, South Sudan, Germany, and Australia are full of racists. They're also full of Sabbath breakers. And it's still not the Sunday Law test. There's a lot of issues the world needs straightening out on. But the test that shipwrecks two institutions, the test that decides your eternal destiny, is not race or the Sabbath; its gender.

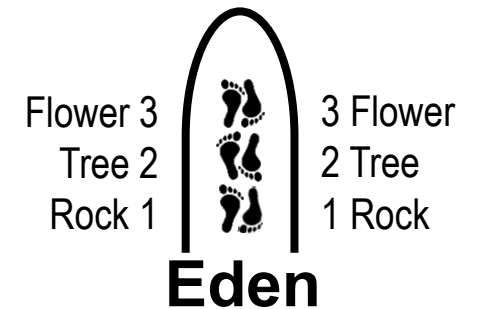

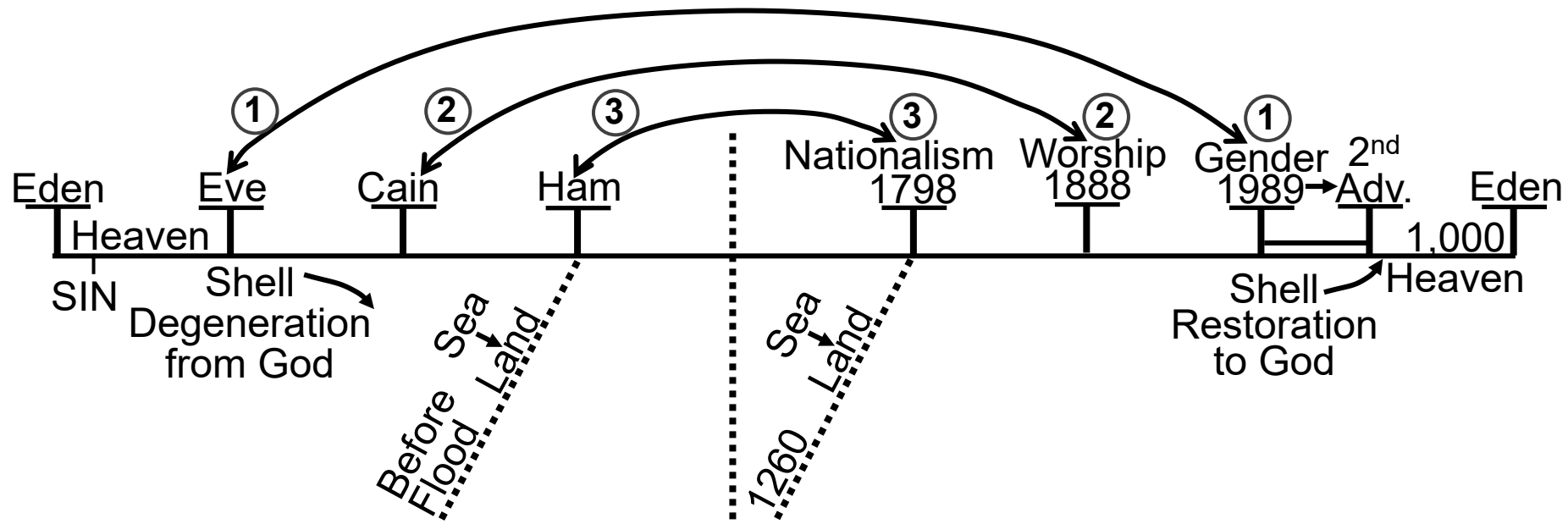

It's with the sin of Eve that our shell began to deteriorate; it's here under the Second Advent that it will be healed. Sin first rose up in Heaven; we're going to have a thousand years there to consider what sin has done to us. Heaven [beginning just after Eden], heaven [end just before Eden]; the chiasm works.

It's the subject of gender that will take us back to the restoration of the shell, back to direct communion with God, back to Heaven.

We're not done with this line of Eden to Eden. I know it's going to be something we continually discuss.

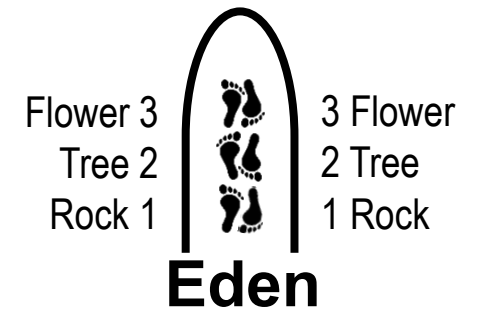

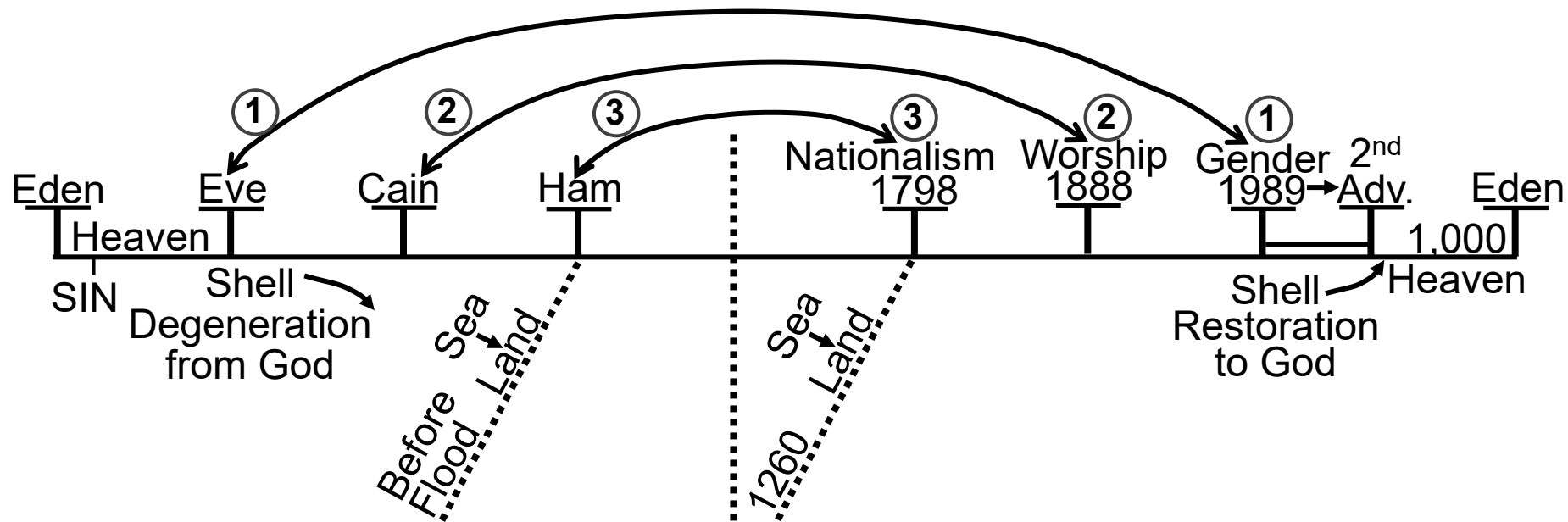

What I want us to consider is how extreme our position on gender equality lays, and how deep set our stereotypes are. Racism didn't go away, it just mutated. And over and over again in this Movement, I see sexism not go away, just mutate. Two years ago, a husband would say, "You will not go visit your friends, because you're my wife and I'm your boss." Now that same husband, he won't say that anymore. He'll say, "I love you so much; don't you know I should be your number one priority. Don't you know Adam and Eve were meant to be everything to each other. I've watched Parminder's studies on relationships, we're all meant to be married and joined at the hip. So, don't leave me. I need to be the recipient of the majority of your love time and attention." All they do is mutate ownership into something that looks more pleasant. The concept of ownership in marriage can mutate into so many different forms. As I've dealt with some cases of this, I've seen how it all comes down to that common concept of ownership.

There are a couple of articles that I thought to reference in this discussion. One is by the Harvard Crimson. The Harvard Crimson is the United States oldest, continuously published, college newspaper. Obviously, the college is Harvard. The newspaper was founded in 1873. So, that's the source we're reading from.

“Take a look around: It seems patently obvious that men and women are different. Men prefer to drink beer and watch football, while women prefer to drink vodka cranberries and paint their nails. Men enjoy earning promotions at work, while women enjoy staying at home and taking care of the children. Given the vast disparity in the choices that men and women make in their hobbies, occupations, and even alcoholic drinks, it sometimes seems like we come from two entirely different planets.

“But what if I told you that many of our choices weren’t actually ours to make? Instead, they were made for us from the moment we are born and the doctor examined our genitals and announced either ‘It’s a boy!’ or ‘It’s a girl!’

“Children who are proclaimed boys will be dressed in blue, grow up in rooms adorned with football wallpaper, shop in the boy’s section of the toy store, build battleships with Legos and play baseball with their father, and watch television shows and see men as scientists, as businessmen, as leaders, as United States presidents.”

“On the other hand, children who are proclaimed girls will be dressed in pink, grow up in rooms adorned with princess wallpaper, shop in the girl’s section of the toy store, bake cookies with toy ovens, push little baby dolls in strollers, experiment with makeup with their mother, and watch television shows and see women as nurses, as models, as mothers, as housewives.

“In this way, our preferences are constructed for us the moment we are born. And even as we grow up, gender roles continue to dictate the choices we make.”

I’m going to paraphrase some. It goes into statistics. “But in the UK less than 10% of nurses are men, and only 21% of computer programmers are women. And these statistics are used to prove a point that men and women are good at different things and prefer different things; particularly that men are better at and prefer STEM subjects. STEM is science, technology, engineering, and mathematics. It creates the idea that men are built for these careers, and women are inbuilt with a preference for nurturing babies and staying at home.”

<p>S - Science T - Technology E - Engineering M - Mathematics</p>

I'll read the next paragraph.

“But that’s simply not true. Despite what people like the author of “Men Are from Mars, Women Are from Venus” would like us to believe, research has actually shown that men’s and women’s brain aren’t that different. There is, in fact, no such thing as a “male” or “female” brain. Men do not have brains that predispose them toward aggression and logic, and women do not have brains that predispose them toward nurturing and creativity.

“The differences that we observe between men and women are a result of nothing more than gender roles—the societal norms that dictate what types of behaviors are acceptable for a person based on their perceived sex.

“We learn gender roles from society even at an early age. As we grow up, we adopt behaviors that are rewarded with praise and hide those that are punished with ridicule.”

So, you have a little baby; you dress him in blue. And every time he says the word tractor, you heap praise on him; and as he grows up with a love of tractors and machinery, you think you've had a great little man. The only reason he keeps saying tractor is because of the praise he gets when he says it. He's learning that, to be happy, what makes him happy, is to fit in that societal construct.

Little girls that run around and shout and throw balls are told they're not ladylike, they're not proper. Sit still; speak quietly. Next paragraph.

“The problem isn’t simply that gender roles are often inaccurate; rather, they are also actively harmful and oppressive. Consider the stereotype that women are less competent in STEM. Research has actually shown that code written by female computer programmers is more likely to be approved by their peers—but only if their gender is concealed.”

S - Science
T - Technology
E - Engineering
M - Mathematics

“Yet, the prevailing belief that women are incompetent coders discourages women from pursuing a career in STEM, simply because they get the message early in life that they don’t belong in that field. As a result, women are still vastly underrepresented in STEM fields. This has disastrous consequences: not only are women shuttered away from high-paying jobs, we as a society are not reaching our full potential for innovation by systematically excluding half the population from STEM.”

“Furthermore, gender roles systematically devalue women’s work. There is a reason why activities such as teaching, childcare, and even housework are paid very little or not at all—they are predominantly performed by women. And the argument that those occupations are paid less only because they are easier and require less skill completely collapses upon closer scrutiny.”

S - Science
T - Technology
E - Engineering
M - Mathematics

It [the article] will give the following example. If you're a doctor in the United States you are viewed with high esteem and you are well paid, but in Russia they view doctors differently. Being a doctor in Russia is “*stereotyped as a caring vocation ‘naturally suited,’*” of course, then to women. So, in Russia the majority of doctors are actually women, therefore in Russia it has become one of the “*lowest paying and poorly-respected professions*” you can have. There is a direct relation between how a profession is held in respect, and how it is paid, and who does it.

Feminism is about destroying the notion that men are from Mars and women are from Venus. At the end of the day, we're all from planet Earth. We're all from one planet. The types of stereotypes I'm reading about, I see so prevalent in our Movement. I was going to go into another stereotype, but I won't for time.

The concept of gender incorporates LGBT as well as women, because it all revolves around the one issue of gender stereotypes. It's so easy for people to say, "black lives matter," and to share the occasional article about women's rights; but we're being prepared for an Eden, where sin can't rise up a second time. Some things will take a thousand years to change; but your willingness to change, is tested here on Earth. You're not tested by a slogan you wear on a shirt, or by an article that you post. Your test is your wife, your daughter, the woman who runs your school where you work, the woman leader in your ministry. And I still see women being pulled in for meetings made to apologize for being bossy by ministry leaders. This wouldn't happen if people understood equality. And the responsibility also falls upon women; the willingness to put self aside and encourage the women around them. Equality seems easy until you come in face to face with a real-life example. As you read it and share it and teach it, it seems easy. And then you come face to face in it, in your own life. I'm always available to speak to. But then time and time again, what seems easy, all of a sudden gets much harder; because we're all built with this model. And when you see a female leader show strength, make a decision, both men and women are programmed to feel uncomfortable. If you don't feel uncomfortable with the message of equality today, perhaps you don't understand it.

This 1 in 123, who were abolitionists, I don't think a tenth of them genuinely believed in equality. We went through that in prior camp meetings; we went through that in Fiji. And then as racism mutated from slavery to Jim Crow, most of those were completely comfortable with that. They stopped fighting for anything more extreme. So, when we come to gender today, if you think you could take this message into the Democrat party and have success, you don't understand this message. We have a very strong position, but it's what's required to get from Eden back to that same condition. Anything less than that, and God just simply doesn't have a choice; you don't get to come through the gate. As a Movement therefore, that is the kingdom, anything that is less than that standard cannot be baptized, cannot be accepted in positions of leadership. And if someone cannot be baptized, all we're saying is they're not safe in the kingdom.

Population U.S. 1860 Census 31,443,321
Abolitionist By the Civil War beginning 255,000 That's 1 in 123.

So, this is where a male member of the Movement writes to me and says, “I do accept equality; you can't see my heart. So, you can't judge me; I treat my wife right, I believe in equality.” If I could enact a parable: If you had a box and there's only one side open on that box, the side facing you, you put in that box a vanilla scented candle; you light it; then you come visit me and you hand me the closed side of that box. I can't see what's inside, but I tell you there's a vanilla scented candle in this box. And you say, “You don't know that, you can't see what's inside the box. Only I can see what's inside the box; you don't know what's in the box. Only God gets to view the heart.” But I know what's in the box, because I hear the crackle; I see the smoke; I smell the vanilla. I know what's in that box. So, people take these quotes that say, ‘only God sees the heart,’ and you forget that every time you open your mouth, you give me all the smoke, all the scent, all the signs, of what's in there. So, when I say, you're sexist, I may not have viewed your heart; but I can be just as sure of myself. And if God didn't think that his people could do that, why would God entrust us with baptism? If I'm not allowed to baptize someone alive, I have to be able to tell who is alive and who is dead. Which means we have to see the heart.

It's time for us to close. God is restoring a kingdom. If you feel uncomfortable, good. But be careful when the articles start to hit your own life; because you're tested based on what happens in your own life, not what you post, not what you wear. And if we can look back at Millerite history and see how correct and beautiful racial equality is, if you can see the beauty in the structures, I hope as hard as some of these things are to hear, you can see beauty.

If you kneel with me, we'll close in prayer.

Dear Lord, how precious that we can meet together. When you start a Movement, it's to teach us; and yet so many people seem surprised when the messages don't just serve to confirm their old beliefs they already had. They expect revelations from you to just tell them they were right all along. Help us see the madness in this. Truth does not come from you just to make us feel better confirmed in what we already believe. May your messages do their work, a real-life work in the members of this Movement, for our own sake in the hearts of both men and women. Not just for our own sake, but for the list of people that each one of us would have the opportunity to save, to bring with us to a new Eden, where these things, these consequences, of sin don't exist. May we see sin as you see it, and learn to hate it. I pray in Jesus's name. Amen.

