

The Midnight Watch



'Communication Technology' and the Gospel
Elder Tess Lambert - August 29, 2020

'Communication Technology' and the Gospel

TMW – Elder Tess Lamber – August 29, 2020

<https://www.youtube.com/watch?v=Z-rBotwyLeo>

References

EGW Writings

- RH, August 27, 1861 par. 4
- 1T 201.2
- SBBS 5.1
- GC88 305.3

Pioneer Writings

- 1855 JNA, TAR 108.1
- 1842 WiM, MWV2 227.2
- 1875 JW, SLWM 142.1
- September 1850 JWe, ADRE 53.5
- 1938 END, FOME 130.1

Opening Prayer

Dear God in Heaven, thank you for our blessings. Thank you for your Sabbath Day. Thank you for how you have cared for us and all that you have done for us. Thank you for your guiding in our past history. We know that you have been faithful to us. I pray Lord that we'll be faithful to you. May we see your past guiding and trust you now; trust you with our futures. I pray as we study these things, we're studying that past guiding and it is designed line upon line to explain and aid us as we live in this challenging time. I pray Lord that we will take hold of these lines, that we'll understand them as you intend us to and that they will anchor us in this Movement in your truth. I pray this in Jesus' name. Amen.



Pax Romana or Why Jesus Came in 4 BC

We have been going on quite some tangents over the last weeks. We've been intending to come around to a study of Millerite history, about Alpha history, but we've been on a number of tangents. So, I really want to get back on track, but we're going to begin with just looking at something that looks disconnected; but it will be connected. I want to come back to the end of Ancient Israel.

Question: **End of Ancient Israel, when does that reform line begin?**

End of Ancient Israel)

Pax Romana or Why Jesus Came in 4 BC

Brendan: Four BC

Elder Tess: Yes.

Question: **What happened in 4 BC?**

End of Ancient Israel)
4 BC)

Pax Romana or Why Jesus Came in 4 BC

Answers in Chat: End of Ancient Israel. Birth of Christ.

Elder Tess: So, this is 4 BC. This is the First Advent.

Why 4 BC?

Answers: Birth of John the Baptist.

Elder Tess: Yes. Why 4 BC? Now there's a number of reasons, but there's one that I'm looking for, and I'm not going to give you any other hints.

Question: **Why 4 BC? Why does God choose that point in earth's history for his First Advent?**

End of Ancient Israel)
4 BC)

Pax Romana or Why Jesus Came in 4 BC

Someone says fourth generation. Someone says because of Rome.

Question: **Why because of Rome? What was it about Rome?**

End of Ancient Israel)
4 BC)

Pax Romana or Why Jesus Came in 4 BC

Answers: Rome united the known world. Political context.
Because the Romans had control of the world. Because the
Roman Empire is all connected.

Elder Tess: Yes. So, the Roman Empire is all connected.

Question: **How long does the Roman Empire extend for?**
How many years?

End of Ancient Israel)
4 BC)

Pax Romana or Why Jesus Came in 4 BC

Answer: 330 AD.

Elder Tess: 330 AD, and it also begins well before then. So, I'm looking for how long a time span.

Answer: 360 years.

Elder Tess: Some people say 360 years; yes, and they're marking that particularly from quite a constricted period of time when it's ruling with that degree of dominion. You could extend it and see the Roman empire as being much larger than that; but I understand why you said the 360, 'a time,' as we're told in prophecy. So, you could make that broader. You're extending it to that 360-year time period; but even then, four BC is quite specific. So, I want to talk just briefly about the **Pax Romana**.

End of Ancient Israel)
4 BC)

Pax Romana or Why Jesus Came in 4 BC

The Pax Romana, the Roman peace, extended from about 27 BC to 180 AD. And within this, about 200-year, time period, you have 4 BC to 100 AD, and that is the reform line of the end of Ancient Israel. So, of the thousands of years that you have, Christ uses that time period for his First Advent. That 104-year time period is neatly condensed within that 200-year Pax Romana.

End of Ancient Israel) • Pax Romano
4 BC)

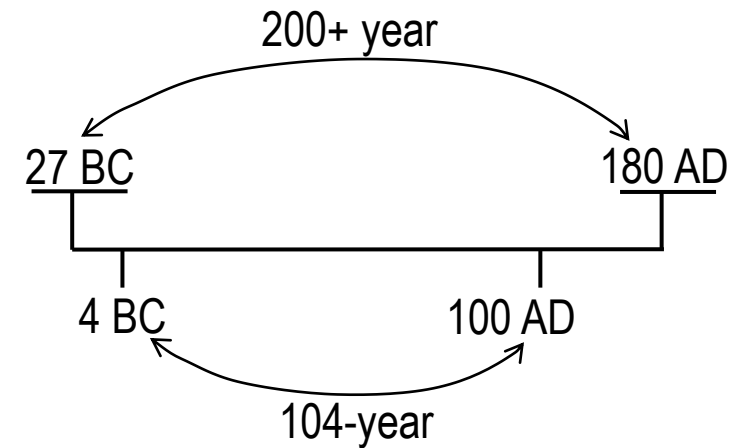

Pax Romana or Why Jesus Came in 4 BC

I'm just going to read a couple of quotes about it.

"That state of general peace which existed throughout the Roman Empire under the prosperous reign of Augustus Caesar, was peculiarly fitted for the advent of the Prince of Peace." {EGW Writings. SBBS 5.1}

End of Ancient Israel) • Pax Romano
4 BC)

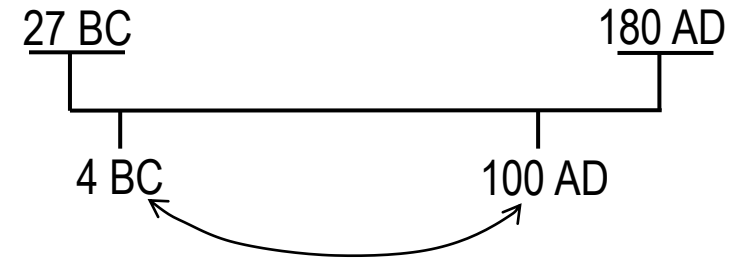

SBBS = Source Book for Bible Students

Pax Romana or Why Jesus Came in 4 BC

“The Pax Romana, which is Latin for Roman peace, is a roughly 200-year long period in Roman history which is identified with increased and sustained inner hegemonial peace and stability though not without wars, expansion, and revolts. It is traditionally dated as commencing from the accession of Caesar Augustus, founder of the Roman principate, in 27 BC and concluding in 180 AD with the death of Marcus Aurelius, the last of the good emperors. Since it was inaugurated by Augustus with the end of the Final War of the Roman Republic, it is sometimes called the Pax Augusta or Augustus’ Peace. During this period of approximately two centuries, the Roman empire achieved its greatest territorial extent and its population reached a maximum of up to 70 million people.” {Wikipedia. Pax Romana}

End of Ancient Israel) • Pax Romano
4 BC)

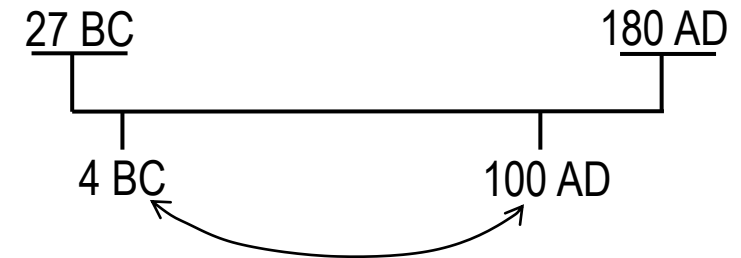

Pax Romana or Why Jesus Came in 4 BC

“The Pax Romana is said to have been a “miracle” because prior to it there had never been peace for so many centuries in a given period of history.”
{Wikipedia. Pax Romana}

So, you might have some peace; you might have a small period of peace, but you're not going to have just about two centuries of peace. When you're going to have a 104-year reform line, when you're going to have that extent of time that's needed for the gospel to come for Christ to have his first advent, to spread throughout the known world, you need that type of time period of peace.

End of Ancient Israel) • Pax Romano
4 BC)

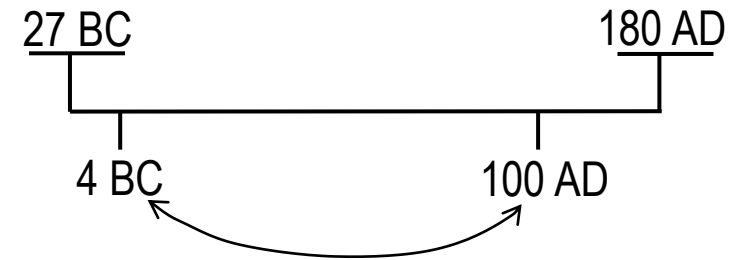

Pax Romana or Why Jesus Came in 4 BC

“Through the triumphs of Caesar, Augustus, Claudius, and Marcus Aurelius, Rome became one of the largest empires that had ever existed, greater than that of Persia, Assyria, and even challenging that of Alexander the Great. However, a territory that large caused many difficulties, many of them costly – riots, rebellions, and insurrections. The solution to many of these problems came under the astute leadership of Emperor Augustus - it was called the Pax Romana or Roman peace.” “He had gained political and military control and built an empire. Augustus secured the borders, stabilized their economy, and brought a sense of peace.” {World History Encyclopedia. Pax Romana.}

End of Ancient Israel) • Pax Romano
4 BC)

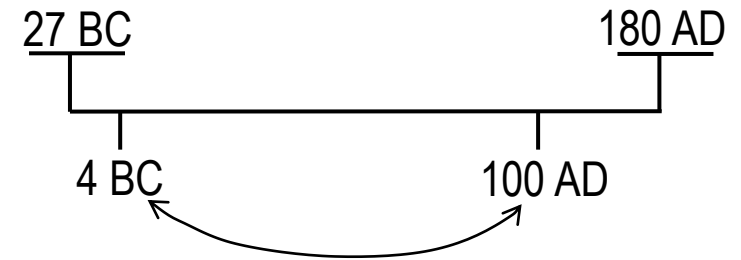

Pax Romana or Why Jesus Came in 4 BC

You can see that what God is waiting for, for that First Advent, is not only was there to be peace but it was also to be a peace that spread throughout as large a territory as was then possible. Under Augustus it reaches this large extent, a maxim of about 70 million people. And Augustus is able to bring peace to that large territory. It's almost as great as the Empire of Alexander.

Question: **Why couldn't Christ come in the time period of Alexander the Great?**

End of Ancient Israel) • Pax Romano
4 BC)

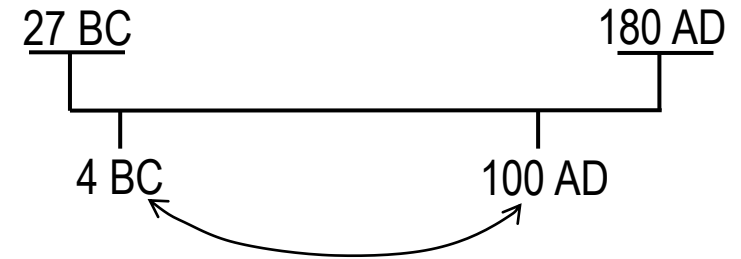

Pax Romana or Why Jesus Came in 4 BC

Because they're all fighting. That fighting never stopped; there wasn't peace. There needed to be this ceasing of war and rebellion, riots and insurrections.

“Under Augustus, they say, even the seas were cleared of pirates, enabling the expansion of trade. New roads - over 50,000 miles of them - made communication easier. Rome was made great again.” {World History Encyclopedia. Pax Romana.}

End of Ancient Israel) • Pax Romano
4 BC)

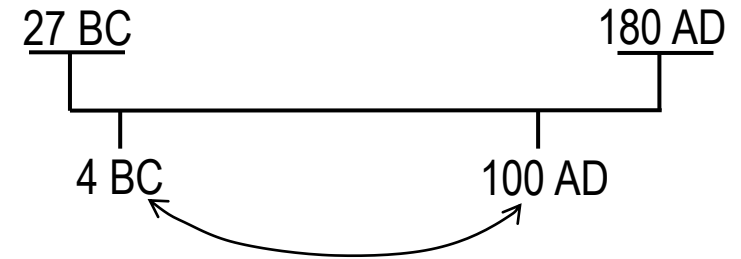

Pax Romana or Why Jesus Came in 4 BC

I don't know why they put that in there. You have peace; but not just peace on land, he's brought peace to the seas, and he cleared the seas of pirates. So, there's peace on land; there's peace on sea. This empire extends to as large a territory as was than possible. And he's also known for the building that he did.

Question: **And what's one of these things being built?**

End of Ancient Israel) • Pax Romano
4 BC)

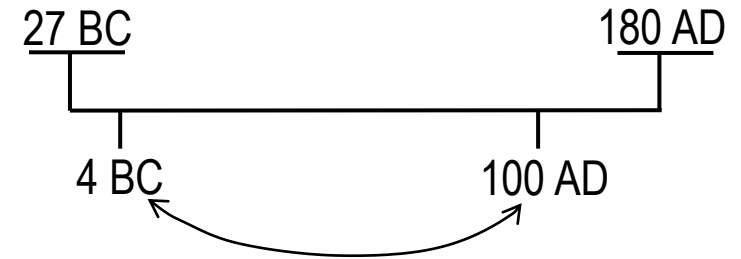

Pax Romana or Why Jesus Came in 4 BC

The roads. So, we're going to go onto the roads as well. Because what were the roads all about? What did the roads make easier? This is all about communication.

End of Ancient Israel) • Pax Romano
4 BC) • Roads - Communication

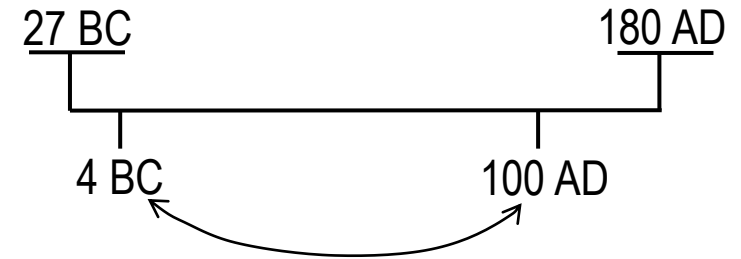

Pax Romana or Why Jesus Came in 4 BC

“New roads - over 50,000 miles of them - made communication easier.” “The Roman people understood and valued the peace and security that Augustus’s new order brought to the empire. To them he became a god, and from this worship emerged the Imperial Cult. Henceforth, an emperor would (with only a few exceptions) be deified after his death.”
{World History Encyclopedia. Pax Romana.}

End of Ancient Israel) • Pax Romano
4 BC) • Roads - Communication

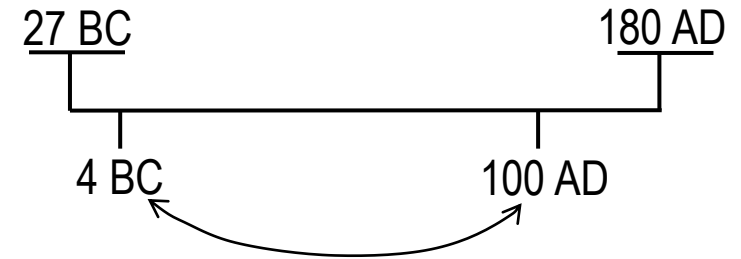

Pax Romana or Why Jesus Came in 4 BC

So, I wanted us to just have a very brief look at the Roman roads.

“In the Itinerary of Antoninus, the description of the road system (after the death of Julius Caesar and during the tenure of Augustus) is as follows: With the exception of some outlying portions, such as Britain north of the Wall, Dacia, and certain provinces east of the Euphrates, the whole Empire was penetrated by these itinera (plural of iter). There is hardly a district to which we might expect a Roman official to be sent, on service either civil or military, where we do not find roads. They reach the Wall in Britain; run along the Rhine, the Danube, and the Euphrates; and cover, as with a network, the interior provinces of the Empire.”

End of Ancient Israel) • Pax Romano
4 BC) • Roads - Communication

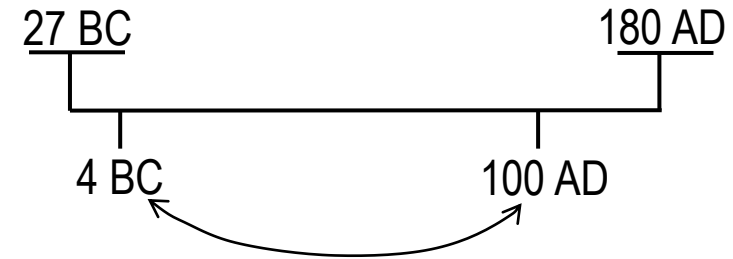

Pax Romana or Why Jesus Came in 4 BC

I just want to share screen for a moment. This is the extent of Roman roads. This is 170 AD, but much of this happened earlier. This is, particularly as we heard described, under Augustus. So, I couldn't find one that was going to give us that time period. This is 170 AD, nearly to the end of Pax Romana. But this is what they already had put in place, and this is the network of Roman roads that extended through that Roman Empire. This was something that was quite new, especially to be done in this way, to this extent.

Note: Sorry, I couldn't find the map Elder Tess was referring to.

End of Ancient Israel) • Pax Romano
4 BC) • Roads - Communication

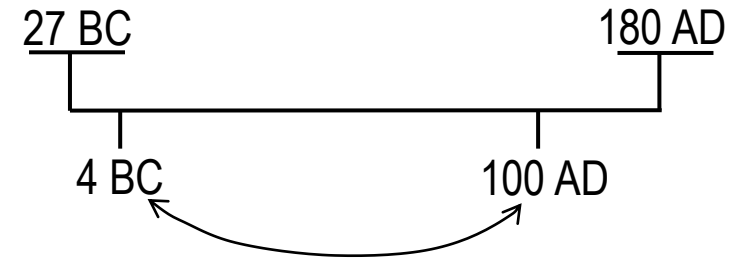

Pax Romana or Why Jesus Came in 4 BC

Note: Sorry, I couldn't find the map Elder Tess was referring to for 170 AD.

This map is from Wikipedia – Roman roads. It is the Roman Empire in 125 AD, highlighting the road system. It is labeled as 'The Roman empire in the time of [Hadrian](#) (ruled 117–138 AD), showing the network of main Roman roads.'

Map image is labelled: [Roman Empire 125 general map.SVG](#)

Found here:

[https://en.wikipedia.org/wiki/Roman_roads#/media/File:Roman_Empire_125_general_map_\(Red_roads\).svg](https://en.wikipedia.org/wiki/Roman_roads#/media/File:Roman_Empire_125_general_map_(Red_roads).svg)



Pax Romana or Why Jesus Came in 4 BC

I want us to see how they built these roads. I don't intend to spend long on this, just to see how technical this was. This wasn't just laying stones. They actually had built up these extensive layers, sometimes quite a few feet of these layers. This one shows a four-layer system, but these roads could extend three feet, four feet, into the ground depending on whether or not they were built on solid land or more damp swamp-like land.

Note: I don't know exactly what picture Elder Tess presented, but it was something like this.

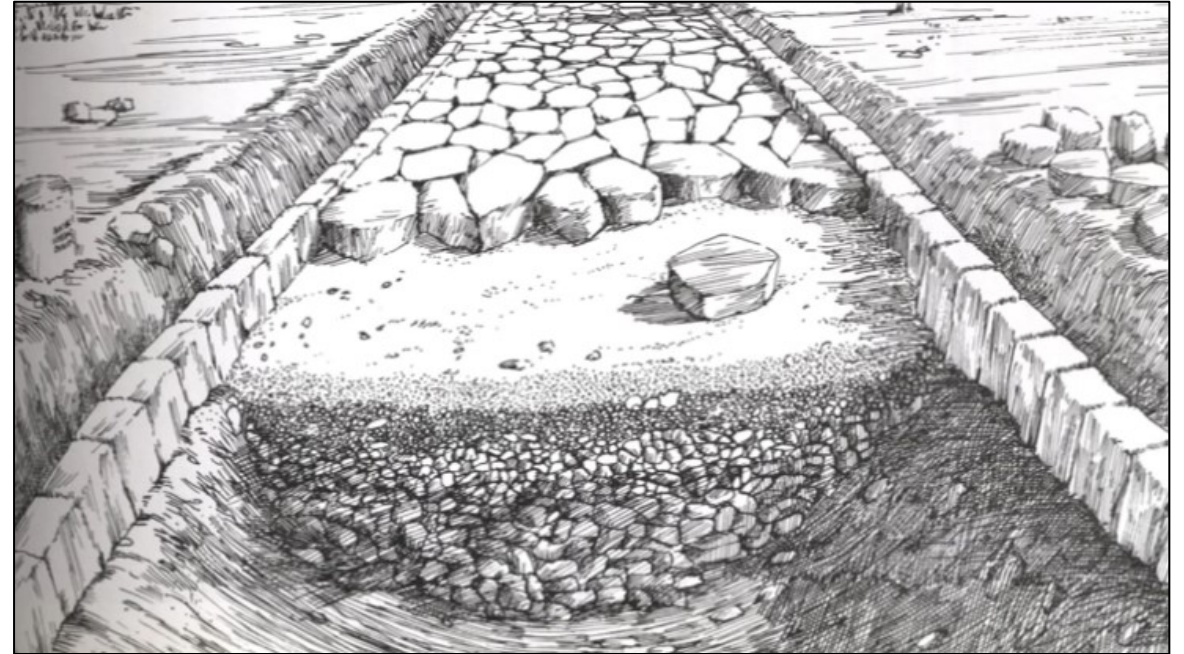

From YouTube Video:

'Were Roman Roads more Durable than Modern Highways'
at 2:24 mins, illustrating the layers of different rock material
used to build the Roman Roads.

<https://www.youtube.com/watch?v=4egCVU3arVk>

Pax Romana or Why Jesus Came in 4 BC

You can see how these roads still stand today. See how polished those stones are by the foot traffic. These roads are so polished; and you can see how years and years and years of those wagon tires have actually created these crevices in the roads, and that was quite normal. So, when you think of how our roads break down today. They didn't just lay stone slabs. This was an extensive work that they did. And honestly compared to how our roads stand up today, this was quite an incredible feat. Some of them lasting thousands of years, two thousand years by now. And you can see the amount of traffic that these roads carried.

Note: I don't know exactly what picture Elder Tess presented, but it was something like this.



From YouTube Video:

'Were Roman Roads more Durable than Modern Highways'

at 3:26 mins, illustrating the top rock layer of the Roman Roads polished by wear.

<https://www.youtube.com/watch?v=4egCVU3arVk>

Pax Romana or Why Jesus Came in 4 BC

Someone says, they probably did not take as much weight as nowadays roads do. Elder Tess: I think they took a lot of weight. When you have horses and carts and loaded carts, when you have the march of infantry, I think they would have had quite a lot of wearing down, and probably a wearing down that was not as evenly placed. Those thin wagon wheels, how they would drive into those cracks in the stones and dislodge. I think it's quite incredible.

Note: I don't know exactly what picture Elder Tess presented, but it was something like this.



From YouTube Video:

'Were Roman Roads more Durable than Modern Highways'
at 3:55 mins, illustrating the width of the Roman Roads to accommodate carts and infantry.

<https://www.youtube.com/watch?v=4egCVU3arVk>

Pax Romana or Why Jesus Came in 4 BC

I just wanted us to see the two things that made this the right time for Christ to come. He had to wait for that time period. He couldn't come in the time of Assyria when they didn't have peace on land or sea, when they didn't have the roads to enable communication to travel. He has to wait until the reign of Augustus, that begins in 27 BC. In 4 BC Jesus comes. And you have from 27 to 180 AD this time period that allowed for the growth and the spread of the gospel.

End of Ancient Israel) • Pax Romano
4 BC) • Roads - Communication

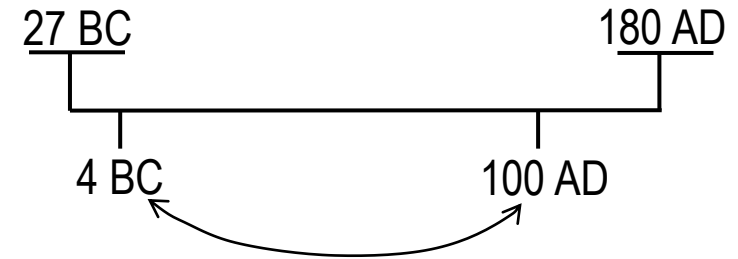

Protestant Reformation

I want to skip down now. We'll move past that to the Protestant Reformation. Now what had to happen? When does the Protestant Reformation take off? Someone give me a date, just a rough date; what year?

End of Ancient Israel)
4 BC) •Pax Romano
•Roads - Communication
Protestant Reformation)

Protestant Reformation

Someone says 1517. Why 1517? Someone says 1529. I'm not saying there's one right answer; but if you can explain in a few words, as you're able, why? Someone says 1518; this is when Martin Luther nails his '95 Theses' onto the door of the Wittenberg Cathedral. 1518; **why 1518?** Why can it happen now? Bob and Penny are going with the Diet of Spires; that's a clever answer, because that's when it's called Protestant. 1518. I'm going to read an article from the library of Arizona Edu.

"In the early sixteenth century, Martin Luther saw the advantages of making his vernacular treatises available cheaply to a growing body of avid lay followers." "Fifteenth-century Europe (this is the 1400s) experienced a technological revolution in the invention of the printing press with movable type that bears comparison with that of computers today."

End of Ancient Israel) •Pax Romano
4 BC) •Roads - Communication
Protestant Reformation)
1518)

Protestant Reformation

So, they, this article, is ignoring the fact that this technology first came up in the east; this wasn't a western invention. This happened in the east. It's one of the many things we tend to attribute to the western world, that actually originally wasn't. But we'll go with this, because they want to talk about Gutenberg.

Side Note:

Created in China, the printing press revolutionized society there before being further developed in Europe in the 15th Century by Johannes Gutenberg and his invention of the Gutenberg press. No one knows when the first printing press was invented or who invented it, but the oldest known printed text originated in [China](#) during the first millennium A.D.

<https://www.history.com/topics/inventions/printing-press>

End of Ancient Israel) •Pax Romano
4 BC) •Roads - Communication
Protestant Reformation)
1518)

Protestant Reformation

Gutenberg lived from 1397 to 1468.

“Gutenberg, a goldsmith by craft, tried to conceal his manufacture of movable type and a machine for printing with it. There were in his day no patents or copyrights to shield the inventor against pirating. The length of time needed to carve the type compelled him to borrow money on which to live, and this eventually catapulted him into bankruptcy. Before the banker confiscated his press and began to use it himself, Gutenberg managed to produce his famed 42-line Bible, dated approximately 1455...”

End of Ancient Israel) •Pax Romano
4 BC) •Roads - Communication

Protestant Reformation)
1518)

Protestant Reformation

So, they expect the bible was completed in 1455. But then from 1455 to 1500 you had this kind of overlap, where a few books were being printed. It wasn't then taking off, while at the same time there were many scribes as well.

“The second half of the fifteenth century was a time of overlapping technologies: scribes continued tediously to copy texts by hand, block books carved page by page from a panel of wood were stamped onto paper, and a few books were printed on the newfangled machines.”

End of Ancient Israel) •Pax Romano
4 BC) •Roads - Communication
Protestant Reformation)
1518)

Protestant Reformation

So, all the way until 1500, you still have this overlap where the scribes are doing a large body of that work.

“Between 1517 and 1546 (I think the correct year may be 1517) [Luther’s reforming career] ... Wittenberg publishers turned out at least 2,721 works, an average of 91 works a year. This represents around three million individual copies, and includes many of the milestone works of the era, not least multiple editions of Luther’s German Bible. This vast blossoming of what was essentially a new industry was entirely due to Martin Luther.

End of Ancient Israel) •Pax Romano
4 BC) •Roads - Communication
Protestant Reformation)
1518)

Protestant Reformation

The presses of other cities turned out thousands of Reformation and a few Counter-Reformation books, pamphlets, and broadsheets of their own. The success of Protestantism over all owed much to printed propaganda. Catholic adversaries of the reform movement never fully exploited the printing press for their own purposes.

Luther's desire to expose the laity to his translation of the Bible and his message in other formats motivated his advocacy of universal childhood literacy."

End of Ancient Israel) •Pax Romano
4 BC) •Roads - Communication
Protestant Reformation)
1518)

Protestant Reformation

This he did as you would expect in a tract, which could be printed, which could be spread on mass.

“At least 11 editions of this tract appeared in 1524 alone in more than seven cities around the holy Roman Empire.”

“As the novelty of the Reformation faded and religious nonconformity became ubiquitous if persecuted, publishing houses” began to focus on other interests, fiction, tracks of scientific discoveries, thoughts, etc.

End of Ancient Israel) •Pax Romano
4 BC) •Roads - Communication
Protestant Reformation)
1518)

Protestant Reformation

The printing press, around 1455; but then all the way until 1500 you still have this overlap. But you need that printing press for what purpose?

So, this is the printing press, and this is all about communication.

So, even for the Protestant Reformation, what's it waiting for? Why isn't it coming 50 years earlier? If it came 50 years earlier, would it have been able to spread? No. When Martin Luther writes his '95 Theses' he can then take it to a printing press, have it printed on mass, and spread through the holy Roman Empire.

End of Ancient Israel) •Pax Romano
4 BC) •Roads - Communication

Protestant Reformation) •Printing Press
1518) •Communication

Protestant Reformation

You needed that advancement of communication technology to be able to have the message spread with power.

Again, the first sentence of that article, *“Fifteenth-century Europe experienced a technological revolution in the invention of the printing press with movable type that bears comparison with that of computers today.”* So, that was how they had their technological revolution that particularly gave them the ability to communicate.

So, Paul was able to travel and communicate through ships on a sea cleared of pirates, and roads laid by the Roman empire. You come to the Protestant Reformation that was able to spread through this new-fangled invention of the printing press.

End of Ancient Israel) •Pax Romano
4 BC) •Roads - Communication

Protestant Reformation) •Printing Press
1518) •Communication

Beginning of Modern Israel

Coming to beginning of Modern Israel.

Questions: **When does that start?**

And what are they going to need?

What are they going to need to help them spread that message, at the very least through their Glorious Land, through the United States?

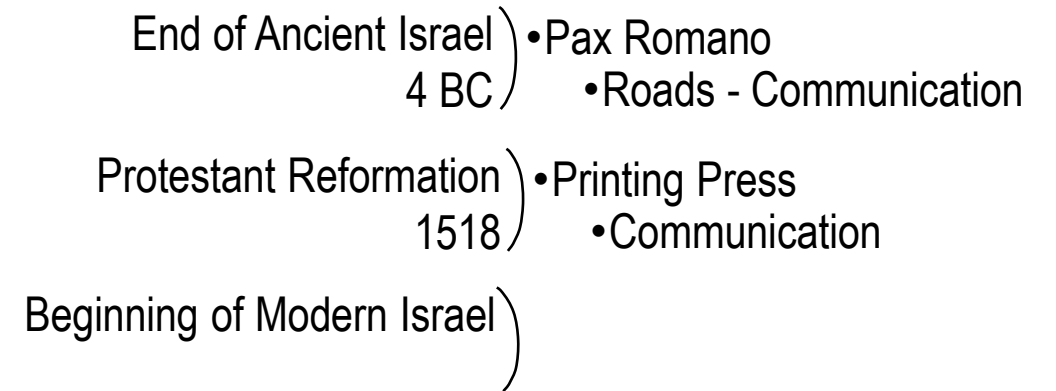

Beginning of Modern Israel

The first steam-powered passenger train began service on Christmas day, December 25, 1830. Why is the first passenger train going to begin December 25, 1830?

Question: **What happens a few months later in 1831? What happens in the Millerite history in 1831?**

End of Ancient Israel) •Pax Romano
4 BC) •Roads - Communication

Protestant Reformation) •Printing Press
1518) •Communication

Beginning of Modern Israel)
1798)

Beginning of Modern Israel

William Miller is months from beginning to spread his message; he's studying on his farm; he's studying in quiet from 1816, really all the way to 1831. In fact, 1831 he begins to travel and teach, and only months earlier, December 25, 1830 the passenger trains are introduced, the first steam-powered passenger service. Between 1830 and 1840, 2,800 miles of track were laid and opened to operation.

- End of Ancient Israel) • Pax Romano
4 BC) • Roads - Communication
- Protestant Reformation) • Printing Press
1518) • Communication
- Beginning of Modern Israel) • Trains
1798)

Beginning of Modern Israel

So, you have those 10 years, from 1830 to 1840, where 2,800 miles of track are laid and are opened up to passenger trains. From 1840 to 1850, 9,000 miles of track are laid; and what happens in 1850, internally? In 1850 they then have to take the message back to the world [remember the 1850 charts]; it's their Sunday Law waymark. From 1850 to 1860, more than 30,000 miles of track are laid.

End of Ancient Israel) •Pax Romano
4 BC) •Roads - Communication

Protestant Reformation) •Printing Press
1518) •Communication

Beginning of Modern Israel) •Trains
1798)

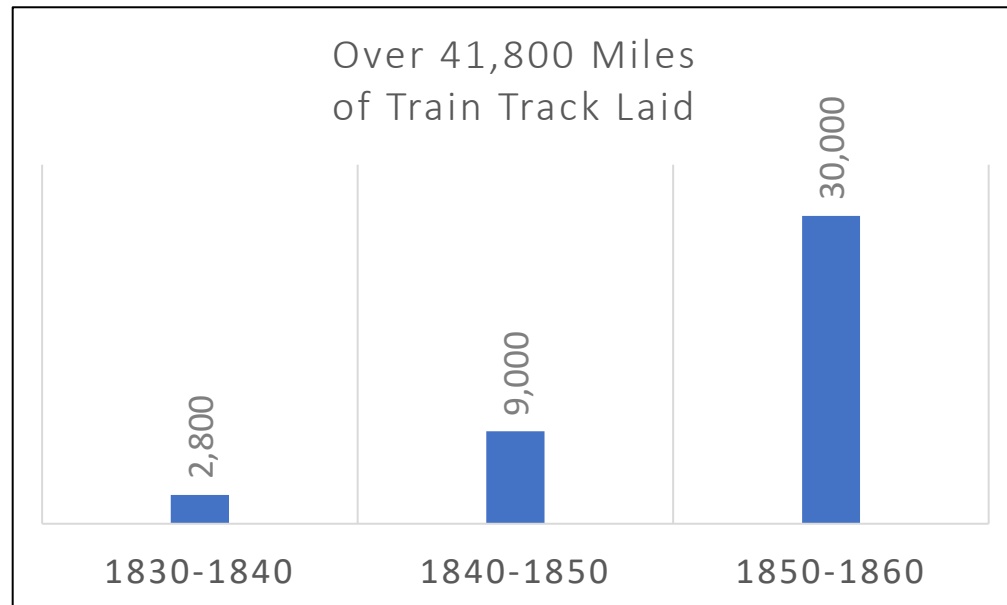

Note: The greatest distance between any two mainland points in the contiguous 48 states (linear distance) is 2,892 miles (4,654 km), from [Point Arena, California](#), to West Quoddy Head, Maine [as the crow flies]. Wikipedia: https://en.wikipedia.org/wiki/List_of_extreme_points_of_the_United_States

Most of these tracks were on the East Coast.

Beginning of Modern Israel

Maps Showing the Progressive Development of U.S. Railroads - 1830 to 1850. From the pamphlet: "AMERICAN RAILROADS: Their Growth and Development," The Association of American Railroads, January, 1951. http://cpr.org/Museum/RR_Development.html

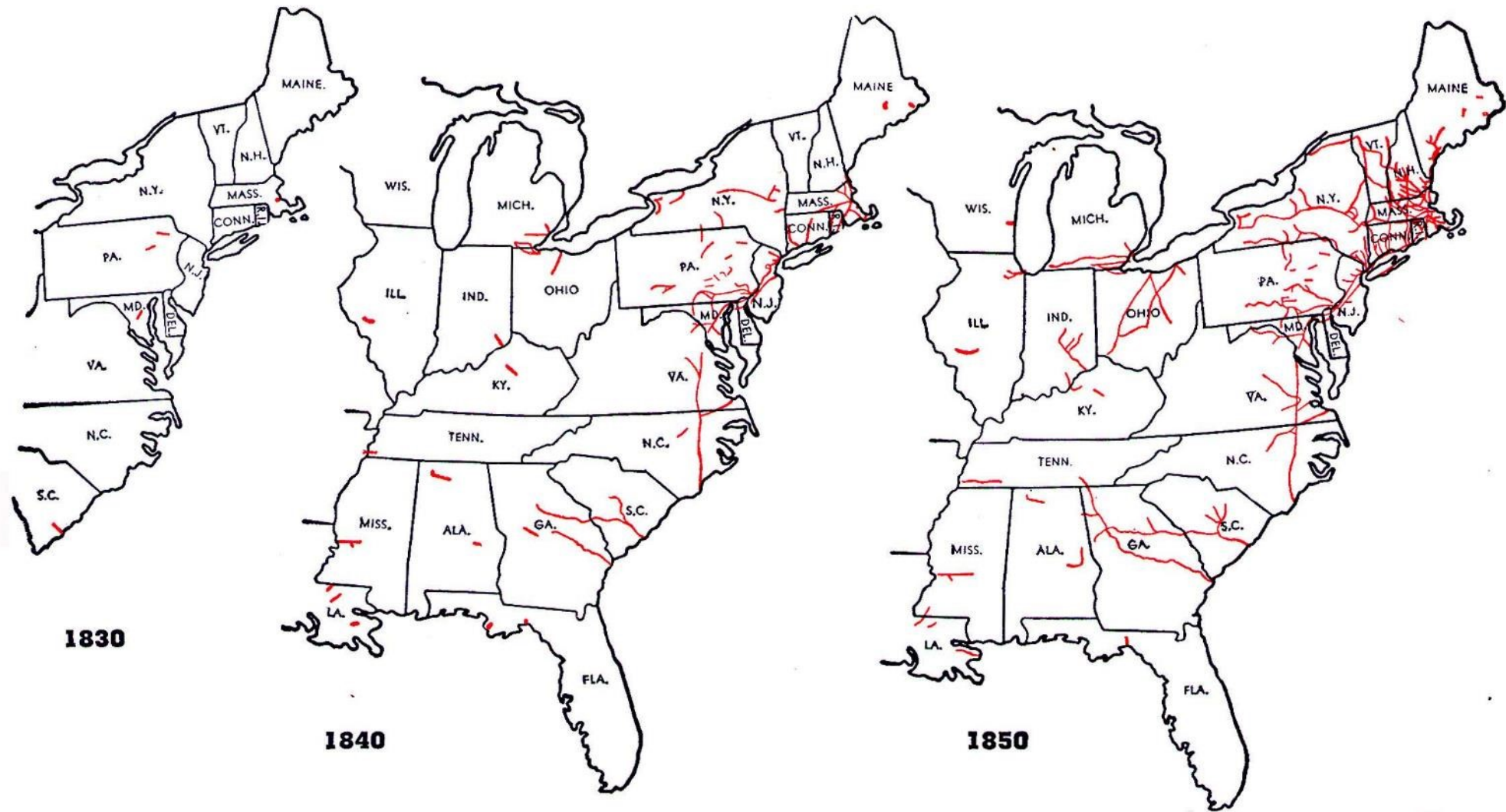

The early stages of railway development in America are shown by this set of maps. During the decade 1830-1840, the total length of completed railroad lines increased from 23 to 2,808 miles, and during the next ten years, more than 6,200 miles of railroad were opened, bringing the total network up to 9,021 miles in 1850. The most intensive growth during this period was in the Atlantic and Seaboard states. In 1850, a trip from Boston or New York to Chicago was made by rail and lake steamers or by stagecoaches, and required several days. One could travel all the way from Boston to Wilmington, North Carolina, by rail, with several changes of cars and a few ferry trips en route. During the first twenty years of railway development, covered by these maps, the population of the United States nearly doubled.

Beginning of Modern Israel

Maps Showing the Progressive Development of U.S. Railroads - 1860. From the pamphlet: "AMERICAN RAILROADS: Their Growth and Development," The Association of American Railroads, January, 1951. http://cpr.org/Museum/RR_Development.html

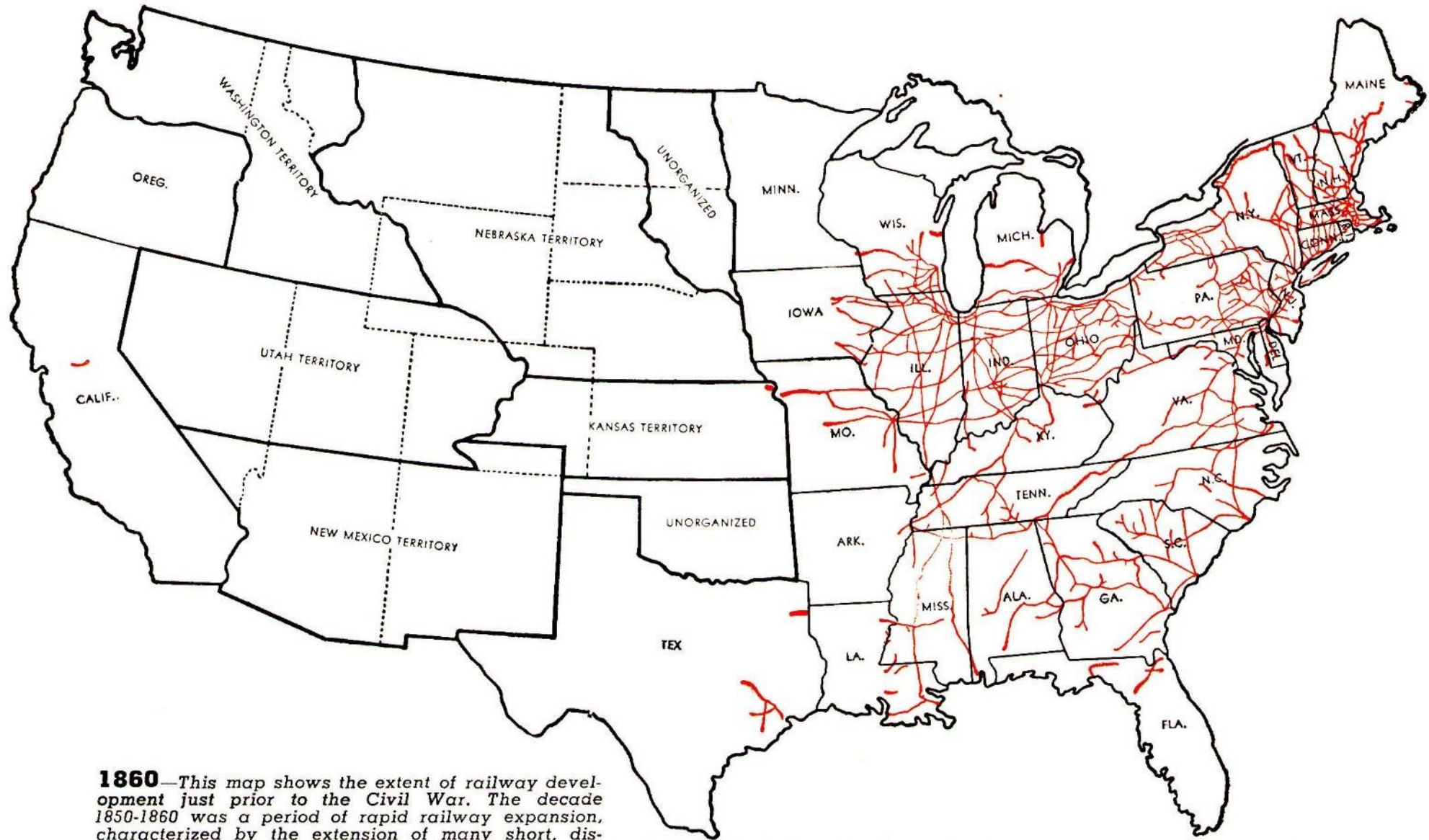

1860—This map shows the extent of railway development just prior to the Civil War. The decade 1850-1860 was a period of rapid railway expansion, characterized by the extension of many short, disjointed lines into important rail routes. This decade marked the beginning of railway development in the region west of the Mississippi River. By 1860, the "Iron Horse" had penetrated westward to the Missouri River and was beginning to make itself felt in Iowa, Arkansas, Texas, and California.

Beginning of Modern Israel

It was between 1850 and 1860 that the railroads grew into a true network serving all of the state's east of the Mississippi. Track mileage more than tripled; the U.S. almost equaled the combined rest of the world in track mileage. So, right when Miller is needing to start teaching his message, you have the introduction of passenger trains, 2,800 miles of track; in 1840 to 1850 there's that first call, 9,000 miles of track; in 1850 you have the second chart, the 1850 chart, printed and they're to go back to the world, and you have a more than tripling, over thirty thousand miles of track laid interconnecting the United States.

- End of Ancient Israel)
 - 4 BC)
 - Pax Romano
 - Roads - Communication
- Protestant Reformation)
 - 1518)
 - Printing Press
 - Communication
- Beginning of Modern Israel)
 - 1798)
 - Trains

Beginning of Modern Israel

From Pioneer Writings, this is James White, I think (actually I'm not sure about that one). I only want one sentence from it. It's talking about William Miller traveling in 1840 speaking about his elections and his journeys. All it says is that, *"by stage and railroad [he] reached his home in Low Hampton on Friday night following, 'being absent from home nearly six months...'"* {1875 JW, SLWM 142.1} So, in that time period he's traveling by stage and railroad.

In 1852 there was a large Millerite camp meeting, where William Miller spoke with Josiah Litch and Joshua Himes. The railroad and the steamboat brought 1,640 people from New York. Of the 6,000 people who attended, 1,640 people came from New York; they came by railroad and steamboat. Why could people gravitate on mass to these camp meetings?

- End of Ancient Israel) • Pax Romano
4 BC) • Roads - Communication
- Protestant Reformation) • Printing Press
1518) • Communication
- Beginning of Modern Israel) • Trains
1798)

JW, SLWM = James White,
Sketches of the Christian Life and
Public Labors of William Miller

Protestant Reformation

In May 1842, a general conference was again convened in Boston. Camp meetings and conferences were being multiplied through the middle and northern states and Canada. And the flying angels or messengers of this judgment hour cry were seen moving with the speed of locomotives on railroads and in steamboats. So, we haven't talked about the steamboat, but that was introduced in the same history; it was also a part of that technological revolution.

- End of Ancient Israel) •Pax Romano
4 BC) •Roads - Communication
- Protestant Reformation) •Printing Press
1518) •Communication
- Beginning of Modern Israel) •Trains
1798)

Protestant Reformation

“...not only on the camp ground but, from the highways, stages, steamboats and rail cars, the songs of ‘Alleluia’ to the Lamb, and shoutings to the most high God, resounded and filled the air as we passed along. ...”

“How was it that the city authorities, and the railroad directors at the Salem depot allowed so many hundreds of these crazy fanatics to fill up their buildings and re-commence their meeting, in shouting and praising the Lord...” {September 1850 JWe, ADRE 53.5}

- End of Ancient Israel) •Pax Romano
4 BC) •Roads - Communication
- Protestant Reformation) •Printing Press
1518) •Communication
- Beginning of Modern Israel) •Trains
1798)

JWe, ADRE = James White, The Advent Review, Volume 1 (September, 1850)

Beginning of Modern Israel

So, you have them gravitating to these camp meetings. But what gives them the ability to do that, is the technological revolution that gave the United States the passenger train, and the steamboat. Many people argue that this technological revolution made more of a difference, made more of a change inside the United States, than the American Revolution had itself.

In 1844, talking about Exeter:

“... As the people on foot, on trains, and in stages, wagons, and buggies, dispersed into the various States, a mighty cry went up throughout New England: “Behold, the Bridegroom comes! ...” {1938 END, FOME 130.1}

End of Ancient Israel) •Pax Romano
4 BC) •Roads - Communication

Protestant Reformation) •Printing Press
1518) •Communication

Beginning of Modern Israel) •Trains
1798)

END, FOME = Everett Newfon Dick,
Founders of the Message

Beginning of Modern Israel

So, after the Exeter camp meeting, how did that message fly through the United States? It was in a large part due to what is known as the 'Market Revolution,' which gave us steamboats and passenger trains. The steamboat was introduced between 1807 and 1811, and by 1837 they had dug 3,000 miles of canals. They dug these thousands of miles of canals so that they could connect different parts in the United States and run these steamboats; that's how a people were also able to travel and spread the message. So, trains and steamboats, and this is all for the communication of the message.

- End of Ancient Israel) • Pax Romano
4 BC) • Roads - Communication
- Protestant Reformation) • Printing Press
1518) • Communication
- Beginning of Modern Israel) • Trains / Steamboats
1798) • Communication

Beginning of Modern Israel

Someone mentioned the telegraph.

Questions: **What year was the telegraph invented?**

And what were the [first] two things that it [transmitted]?

What was the first message?

And, what was the second?

End of Ancient Israel) •Pax Romano
4 BC) •Roads - Communication

Protestant Reformation) •Printing Press
1518) •Communication

Beginning of Modern Israel) •Trains/Steamboats/Telegraph
1798) •Communication

Beginning of Modern Israel

1844.

‘What hath God wrought.’

And then what was it going to spread? Who had won the 1844 election.

You can't disconnect the external political processes of that history from the spread of the message. We have taken part in Miller's mistake, when we ignore the external events.

End of Ancient Israel) •Pax Romano
4 BC) •Roads - Communication

Protestant Reformation) •Printing Press
1518) •Communication

Beginning of Modern Israel) •Trains/Steamboats/Telegraph
1798) •Communication

End of Modern Israel

End of Modern Israel.

Question: **When did that start?**

And what was needed to spread the message?

End of Ancient Israel) • Pax Romano
4 BC) • Roads - Communication

Protestant Reformation) • Printing Press
1518) • Communication

Beginning of Modern Israel) • Trains/Steamboats/Telegraph
1798) • Communication

End of Modern Israel)

End of Modern Israel

End of Modern Israel, 1989. It is evidence, in and of itself, that we are at the end of world's history, that God has a message that needs communicating. The one solid evidence for that is our own technological revolution, the 'Internet Age,' the 'Information Age,' because this is all about communication.

So, you know that when we have such a revolution under the 'Information Age' as the World Wide Web, that there's a message God is wanting to spread. First, it began with the road networks under the Roman empire. Then we gained the printing press. Then we gained the trains, steamboats, telegraph. Then we gained the internet, the World Wide Web. These are all the main steps in the advancements of communication; and they all come at the right time period when God has a message that he wants to communicate.

- End of Ancient Israel)
 - 4 BC) •Pax Romano
 - Roads - Communication
- Protestant Reformation)
 - 1518) •Printing Press
 - Communication
- Beginning of Modern Israel)
 - 1798) •Trains/Steamboats/Telegraph
 - Communication
- End of Modern Israel)
 - 1989) •WWW
 - Communication

End of Modern Israel

Prior to 1989 Adventism is neck deep in conspiracy theories. They have the Great Controversy. They have all of those things. The spread of the Great Controversy today, the spread of conspiracy theories today, is not the message that God needs and wants to communicate of itself. The conspiracies certainly aren't, and the Great Controversy needs explaining. God needs a Movement. This was a movement, End of Ancient Israel, three fractals, then their template line. Protestant Reformation was a movement. Beginning of Modern Israel was a movement. End of Modern Israel was a movement. Four movements.

- End of Ancient Israel) • Pax Romano
4 BC) • Roads - Communication
- Protestant Reformation) • Printing Press
1518) • Communication
- Beginning of Modern Israel) • Trains/Steamboats/Telegraph
1798) • Communication
- End of Modern Israel) • WWW
1989) • Communication

End of Modern Israel

We have members today turning from this Movement to learn from Adventist pastors and Protestant speakers. What are they doing??

If you think an Adventist pastor is going to teach you 'Righteousness by Faith,' put yourself back in one of those movements. If you're a Millerite and it's 1845 and you're going to go and sit at the feet of a Protestant pastor, what's the problem with that Protestant pastor? He rejected the 2,300 days prophecy. He rejected the chart. And who is he praying to? Do you think he's going to explain anything about the character of God? The nature of the kingdom?

- End of Ancient Israel)
 - 4 BC)
 - Pax Romano
 - Roads - Communication
- Protestant Reformation)
 - 1518)
 - Printing Press
 - Communication
- Beginning of Modern Israel)
 - 1798)
 - Trains/Steamboats/Telegraph
 - Communication
- End of Modern Israel)
 - 1989)
 - WWW
 - Communication

End of Modern Israel

If you're back in 32 AD, after the Cross, you're a disciple, you're going to go and sit at the feet of a Pharisee?? There is no salvation outside of that movement. If you're a disciple, can you go back and say I'll take some of the parables, the part that I like, and I'm going to mix it with what my favorite Jewish Pharisee teaches, mold the two and create my own truth; is that safe?

Protestant Reformation, you're going to take a little bit of that Protestantism and a little bit of Catholicism; is that safe? That's what they did! That's why they were not a success! This does not come under the same category as the Beginning and End of Ancient Israel, and the Beginning and End of Modern Israel. Because even Martin Luther took a bit of that truth and then someone said what about the Sabbath? And what did he say? I'm happy with Sunday. He kept his part of Catholicism and he tried to blend the two. And the Protestant Reformation, as far as bringing about a new church, was a failure.

- End of Ancient Israel)
 - 4 BC) •Pax Romano
 - Roads - Communication
- Protestant Reformation)
 - 1518) •Printing Press
 - Communication
- Beginning of Modern Israel)
 - 1798) •Trains/Steamboats/Telegraph
 - Communication
- End of Modern Israel)
 - 1989) •WWW
 - Communication

End of Modern Israel

You come down to the Beginning of Modern Israel. Could the Millerites do that, take part of Ellen White's message and then mix it with some Protestant pastor (because they liked the way he spoke because his conspiracy theories fitted their world view)?

I want to be clear; because that's occurring more and more through the Movement in Australia and in Oceania, who is particularly our audience today [she was referring to that particular presentation]. If you're doing that, you're walking off the path and that's life and death. There is only salvation inside this Movement. That sounds like exclusivity; it always has been, because the choice is always between life and death.

- End of Ancient Israel) • Pax Romano
4 BC) • Roads - Communication
- Protestant Reformation) • Printing Press
1518) • Communication
- Beginning of Modern Israel) • Trains/Steamboats/Telegraph
1798) • Communication
- End of Modern Israel) • WWW
1989) • Communication

End of Modern Israel

So, we have the 'Information Age;' we have the World Wide Web; we are locked down under a pandemic, and the message still can spread. I don't know how many current countries or continents we have represented today; I know Africa is; I know North America is; I know somewhere in South America is. We have multiple continents connected at one point in time. We should stop and think, not only that that is so incredible, but why is that happening? Because as far as 6,000 years of earth history, we've only had that for a few decades, a couple of decades. And the reason that we've only had that for a couple of decades is because it came right on time. Because now there is a movement that needs to go worldwide. So, I wanted to lay that down before we go into Millerite history, because when we look at Millerite history, we need to see it in all its context.

- End of Ancient Israel) • Pax Romano
4 BC) • Roads - Communication
- Protestant Reformation) • Printing Press
1518) • Communication
- Beginning of Modern Israel) • Trains/Steamboats/Telegraph
1798) • Communication
- End of Modern Israel) • WWW
1989) • Communication

End of Modern Israel

I want to be clear, that as I say certain things, as I make certain points, I'm not necessarily making application. What I want people to have, is a greater familiarity with the external events that happened in Millerite history. And the danger is, that in mentioning an external event, people may think that I am making application. If I make application, I'll try and be explicit that that is what I'm doing. But there's a lot of this history that I would encourage us just to become familiar with so we get some context.

- End of Ancient Israel) • Pax Romano
4 BC) • Roads - Communication
- Protestant Reformation) • Printing Press
1518) • Communication
- Beginning of Modern Israel) • Trains/Steamboats/Telegraph
1798) • Communication
- End of Modern Israel) • WWW
1989) • Communication

End of Modern Israel

Someone asks, “Should we not hear Adventist pastors? Does that apply only for us, or does it apply to the Levites too?”

Elder Tess’ Answer: The Levites don't have much of a choice, although I think many are already coming in contact with the existence of this Movement. We should not be going to Adventist pastors looking for light; they have none.

Imagine back to End of Ancient Israel after the cross, what happened to the veil in that temple? Is there any light left in that place? No. The Levites should be learning from the external events, I would suggest, more so than their pastors. The difficulty with looking to their pastors is, even the ones on that seem on the right side, it’s usually such a mixture of truth and error. I think it's more dangerous than identifying correctly the external events.

- End of Ancient Israel)
 - 4 BC) •Pax Romano
 - Roads - Communication
- Protestant Reformation)
 - 1518) •Printing Press
 - Communication
- Beginning of Modern Israel)
 - 1798) •Trains/Steamboats/Telegraph
 - Communication
- End of Modern Israel)
 - 1989) •WWW
 - Communication

Our Alpha History

I want us to look at our Alpha history. I'll draw our Omega. 1989, 9/11, Sunday Law, Close of Probation, Second Advent. So, we just want to do a short compare contrast. And since I really don't want to go over time today, we're not going to do too much more. But I just want to make a suggestion, something for us to think about. This is the Omega line. I've put it above our Alpha. In 1798 there was an Increase of Knowledge and in 1989 there was an Increase of Knowledge. Both the Increase of Knowledge for the Alpha in 1798 and the Increase of Knowledge for the Omega in 1989, was based on the Unsealing of the Book of Daniel.

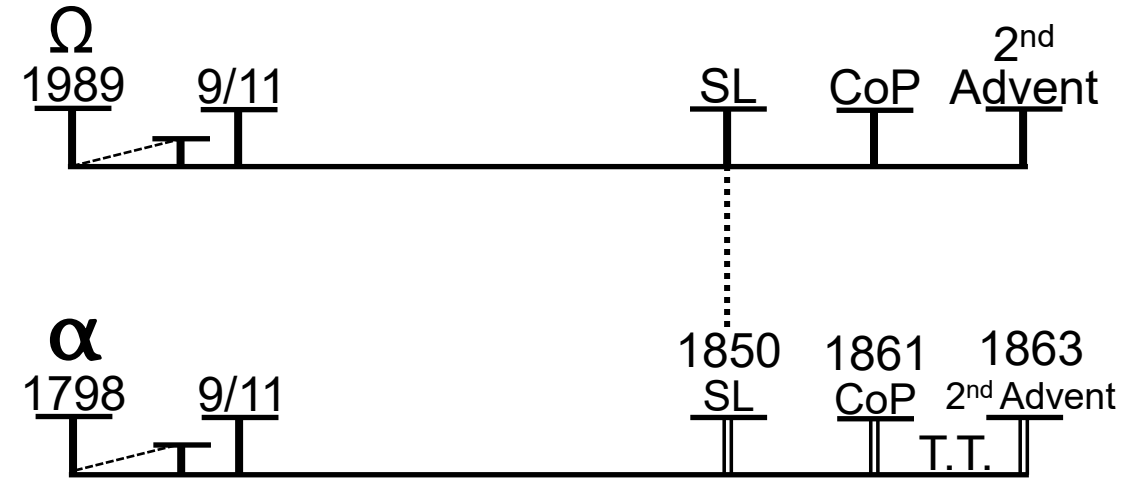

Our Alpha History

When was this line first laid out, this bottom one, with 1850 for the Sunday Law waymark? I don't have a great memory; but I think it was at the German International camp meeting, which was a year ago now [2020]. It's exactly a year since that camp meeting. So, we've already been discussing in this Movement for some time now the importance of 1850, and how it lines up with the Sunday Law. And then identifying 1861 as the Close of Probation, 1863 as the Second Advent. And that was meant to occur in this Time of Trouble, that occurred under the American Civil War.

So, if we can do a short compare and contrast of these two histories. Ellen White says in the Great Controversy,

“The 1260 days, or years, terminated in 1798. A quarter of a century earlier, persecution had almost wholly ceased.” {GC88 305.3}

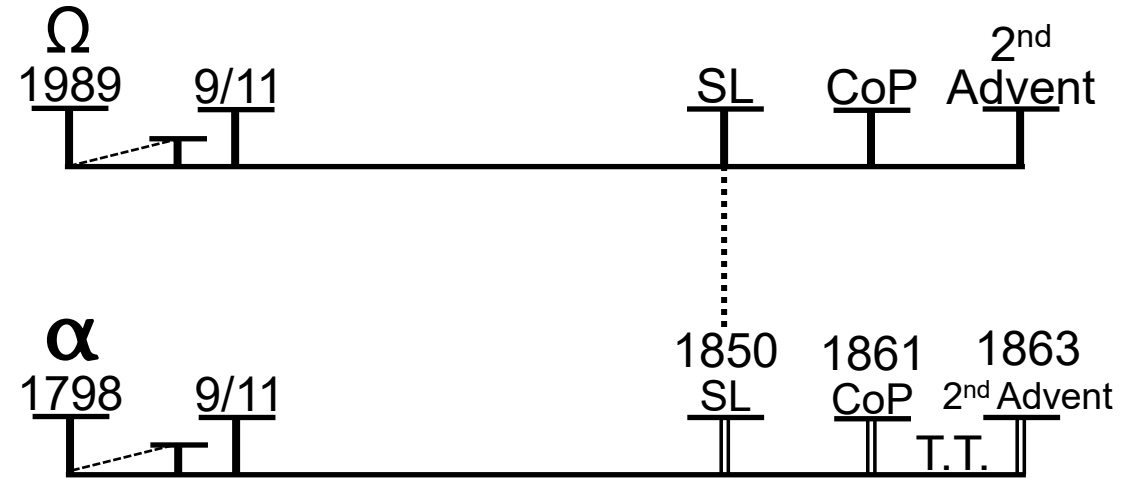

Our Alpha History

Twenty-five years before 1798, takes you to 1773. And what happened here was the abolishment of the Jesuit order; and this caused not a complete ceasing, but a large ceasing of the persecution that had occurred during the 1260.

Question: **When we come to our line, what are we saying this Sunday Law is about, now that we're heading to the End of Ancient Israel? What are we saying its theme is?**

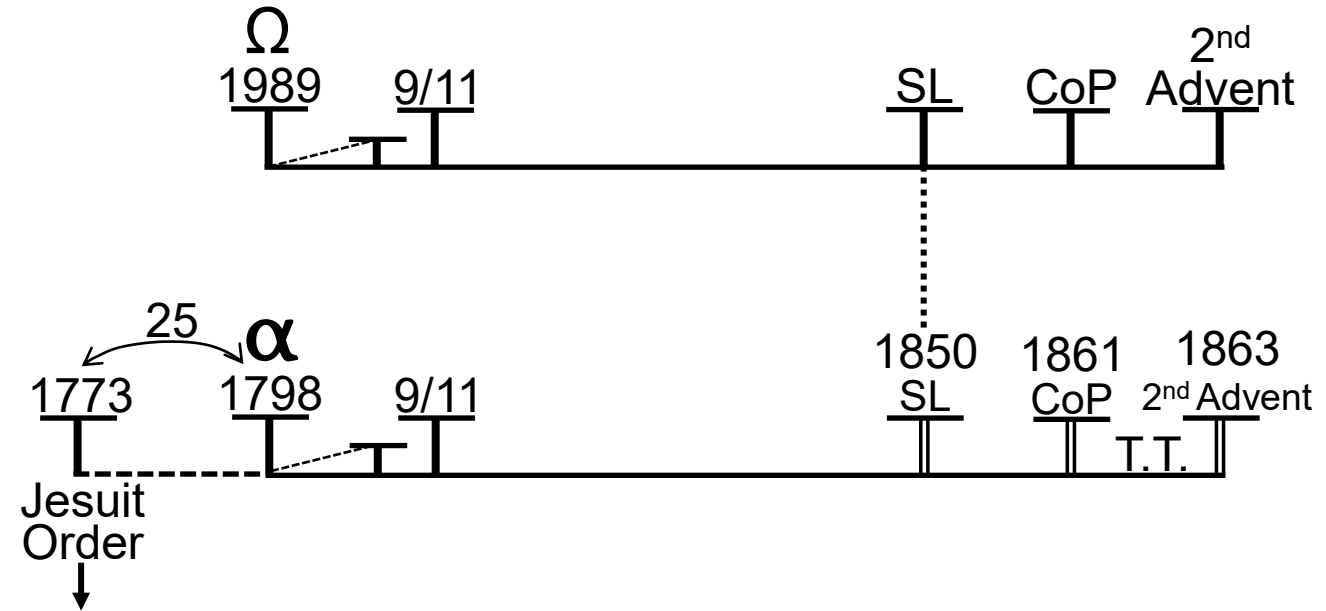

Our Alpha History

So, the persecution almost wholly ceased here in 1773, but what's going to happen is... This Alpha line is a line of failure; we can't forget we need to make a contrast. It's an Alpha history, therefore it is a contrast. It's a line of failure, therefore it's a contrast. So, if there's internal failure, what do you expect externally?

Failure.

So, not only did the Millerites, the Adventists, fail in their mission, but the external movement driving slavery in the United States, it also failed. This 1850 compromise was largely a failure when the northern states failed to enforce it.

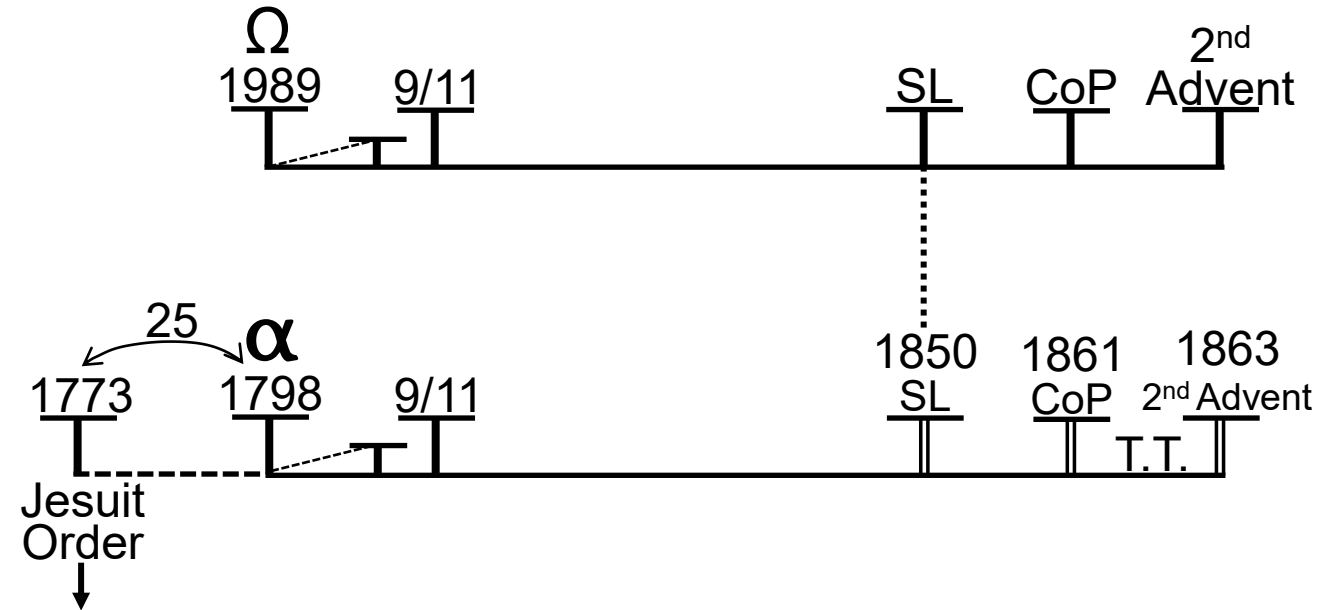

Our Alpha History

We'll discuss that more. So, we need to remember that this line is failure. Persecution ceases here at 1773, but then **what was to come in this time period of 1850?**

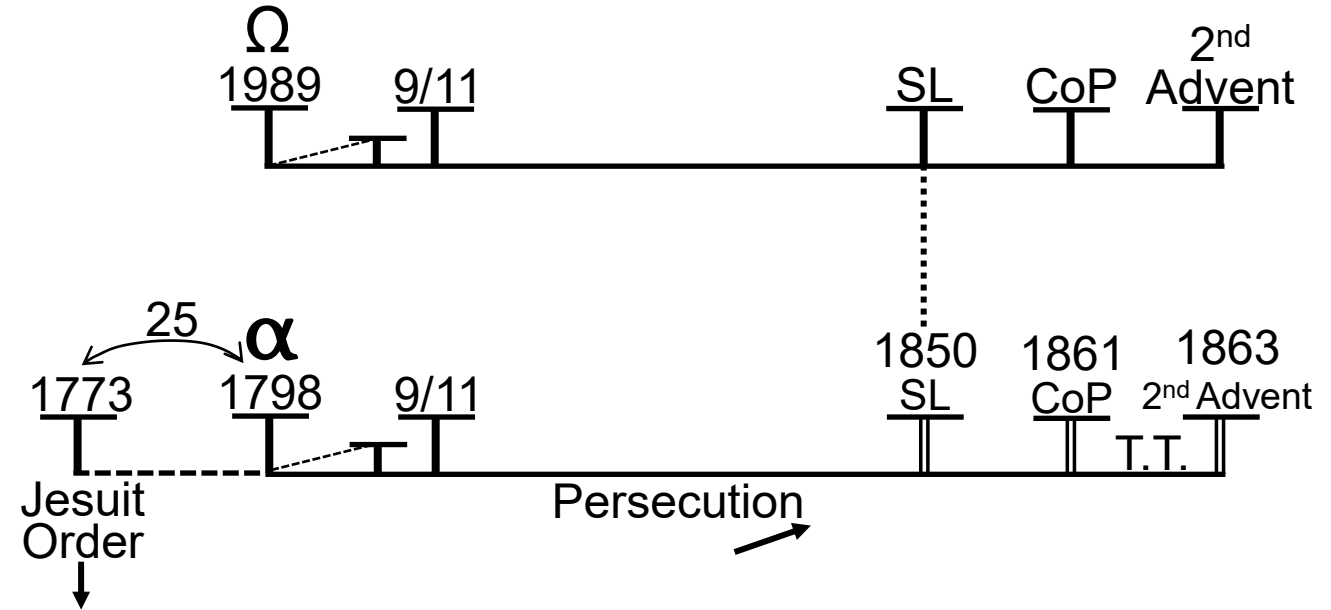

Our Alpha History

That persecution was going to rise up again. So, persecution almost wholly ceases by 1773, but not completely. Elder Parminder has discussed what happened in the French revolution, that was also persecution from a different form. But then you know persecution is going to arise again.

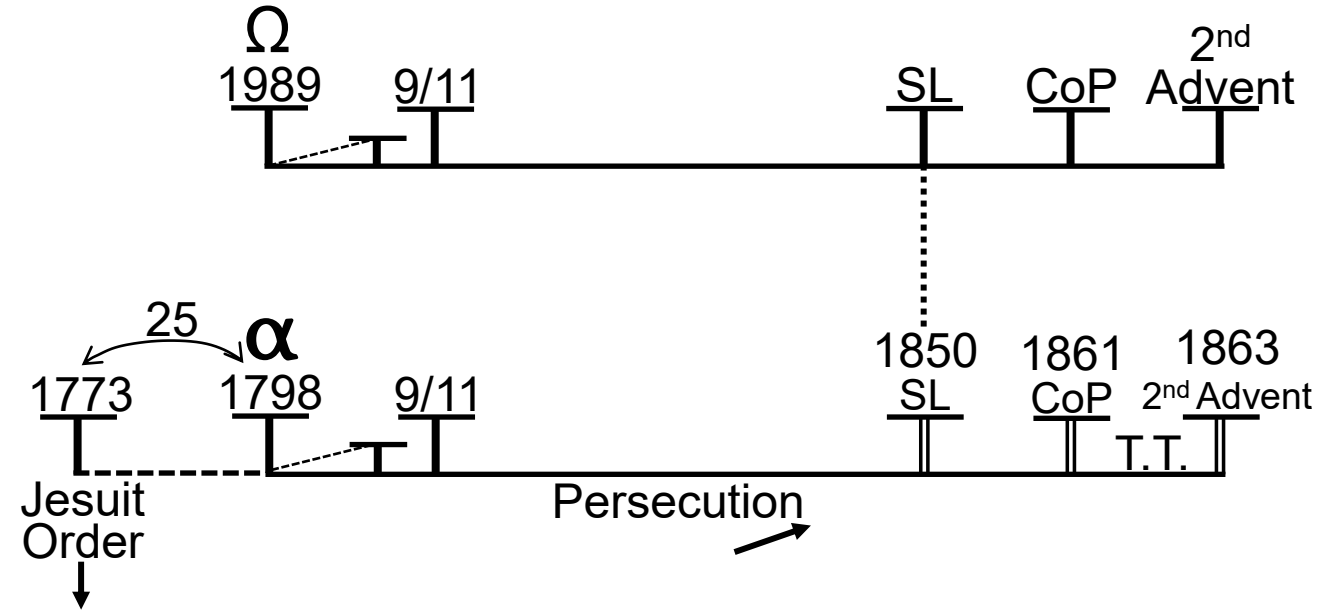

Our Alpha History

In our own history, what's 25 years before 1989? What have we said this Sunday Law issue is about? Going back to that German International camp meeting, **what's the Sunday Law issue about?**

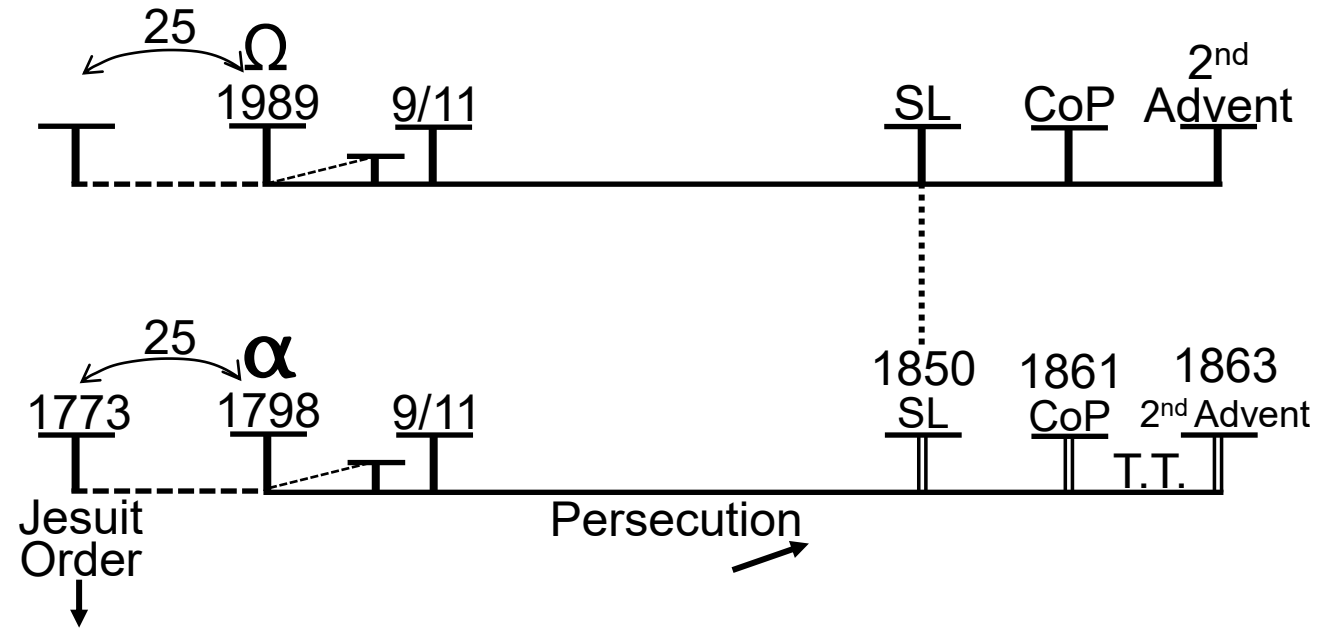

Our Alpha History

Equality.

So, 25 years before, persecution almost wholly ceased, not entirely. It died down and it's coming back up.

What happened 25 years before 1989? It was 1964

Question: **What happened in 1964?**

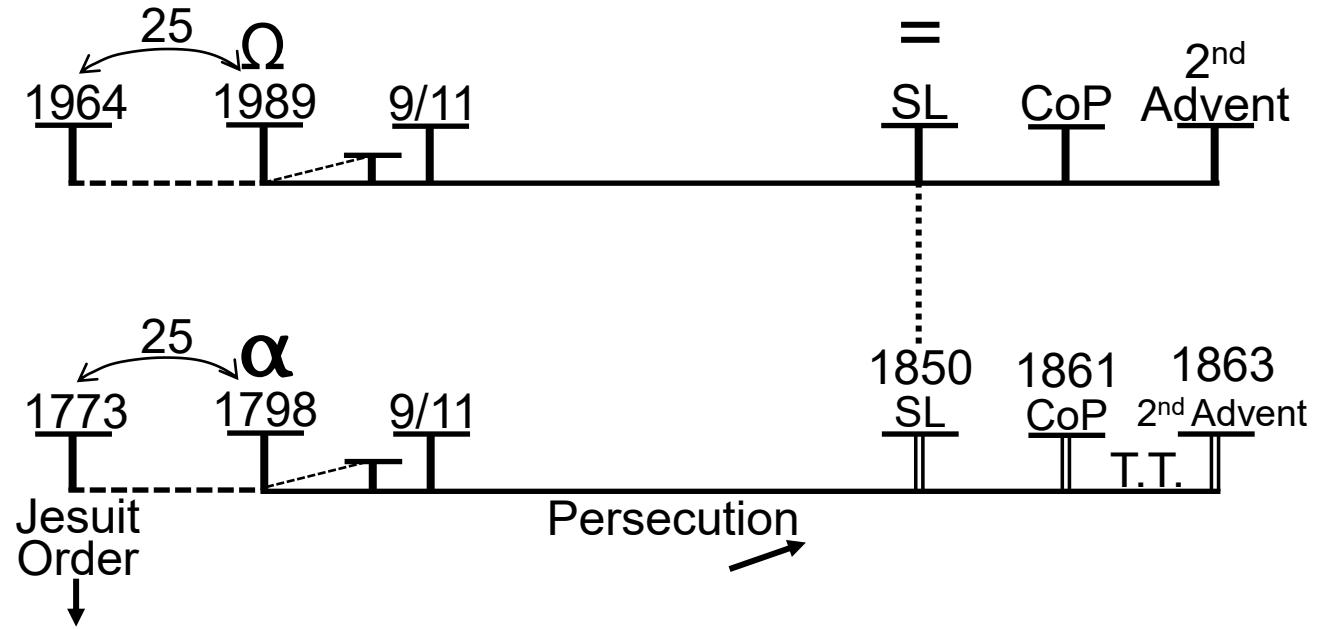

Our Alpha History

Civil Rights Act.

This is the Civil Rights Act of 1964, the prevalent Civil Rights Act.

So, 25 years, a quarter of a century, before 1989 and the Increase of Knowledge is a Civil Rights Act, which ended segregation in public places and banned employment discrimination on the basis of race, color, religion, sex, or national origin. It's considered one of the crowning legislative achievements of the civil rights movement.

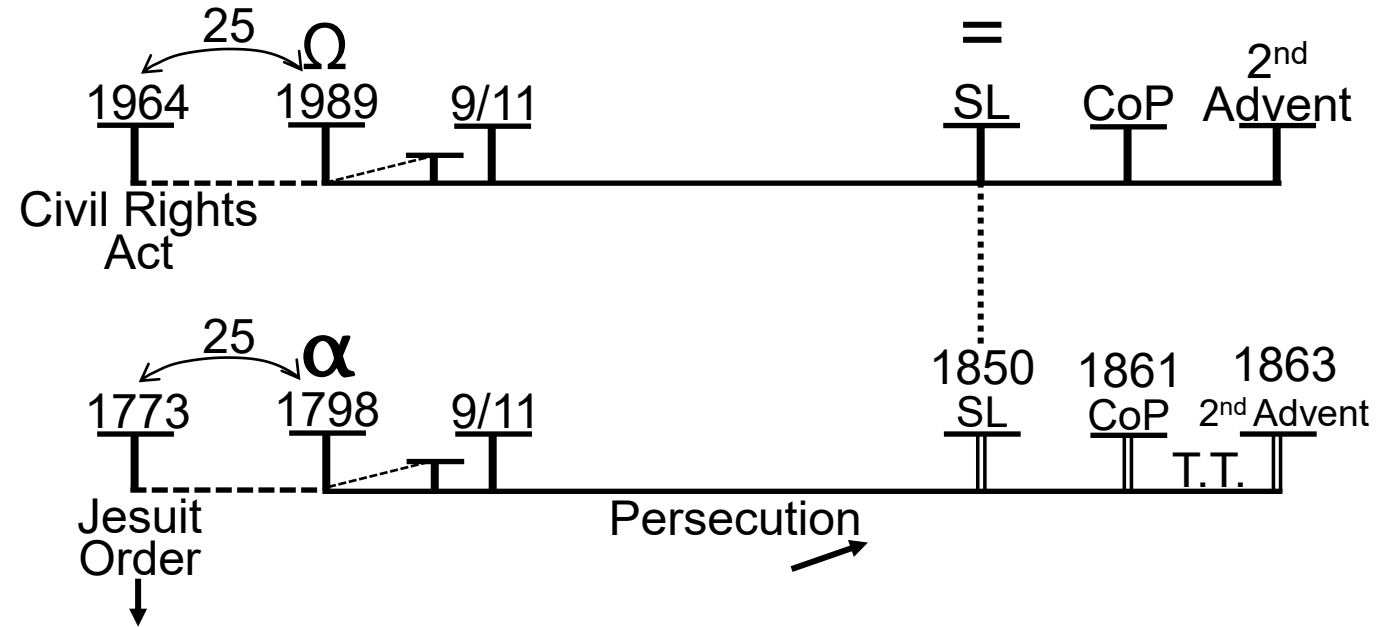

Our Alpha History

So, 25 years before our 'Time of the End,' persecution, not entirely but largely, ceased under the Civil Rights Act. The argument since is, just like the Constitution, just like the Declaration of Independence, who does it apply to?

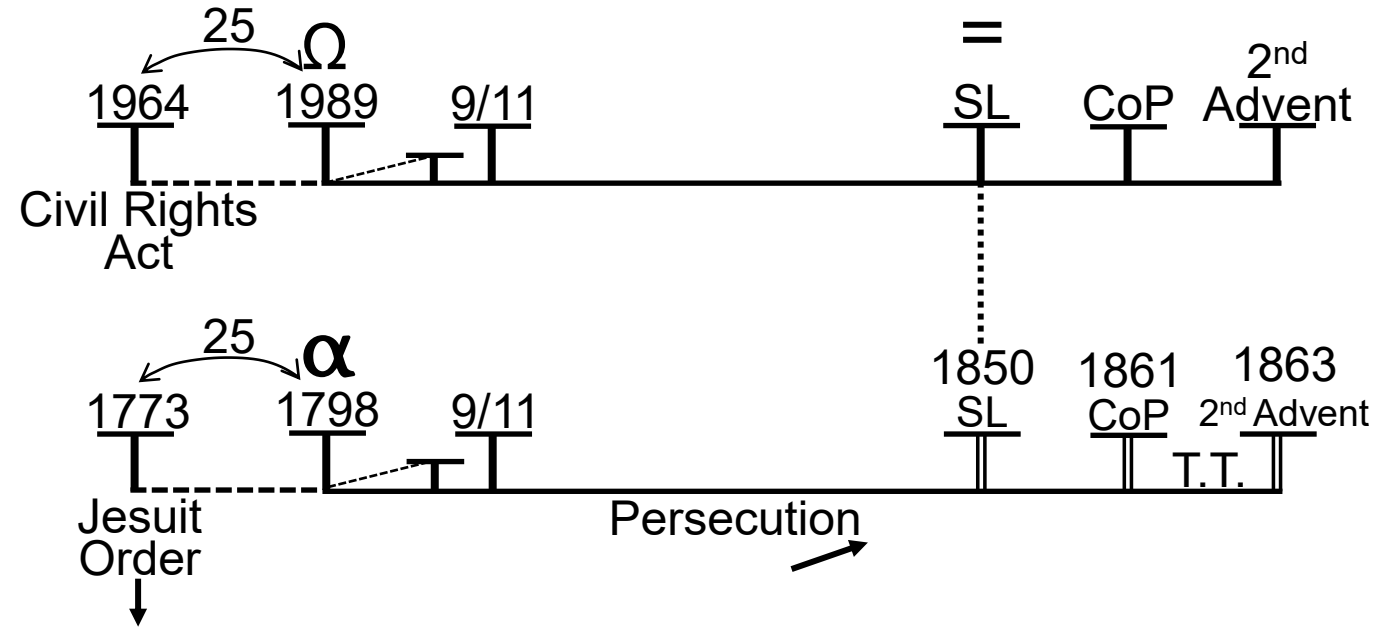

Our Alpha History

The Declaration of Independence and the Constitution, in their sometimes vague wording, should be used as intended for all. The Civil Rights Act should be read as intended for all. And the debate happening now is about what? Who does it really apply to, and how far does it really extend.

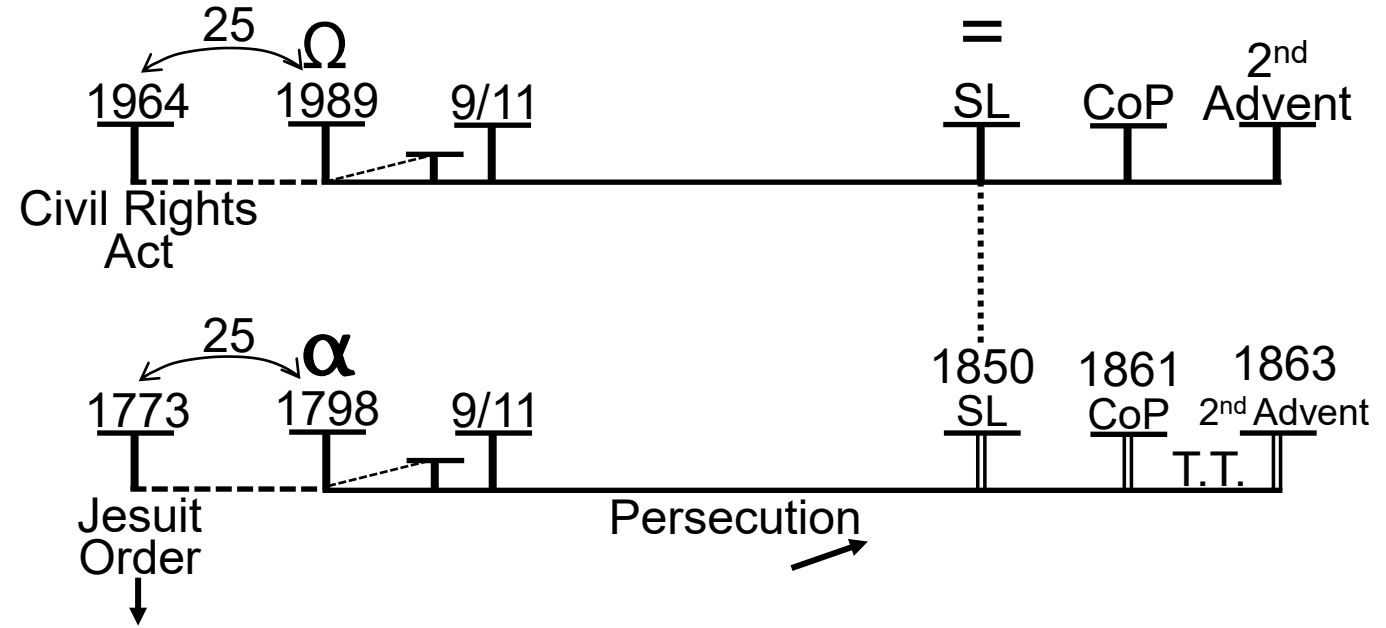

Our Alpha History

So, you have, even just in the last months, and this happened particularly under the U.S. Secretary of State, Mike Pompeo, his commission on unalienable rights. And what did his commission come to?

He believed there were original rights; and then in the words of that commission it became a proliferation of rights, suggesting that now there's too many. Now it's gone too far. These rights were not meant to be extended to everyone with the type of completeness that we would argue they should be read as. So, when you come back to the Civil Rights Act, it extended to women, it extended to people from different countries, it extended to immigrants, color, black and white (of course it's the Civil Rights movement, so that's the crowning context), religion.

But also what was the debate last year [2019], into this year [2020]? (Hint: think on the lines of Gender)

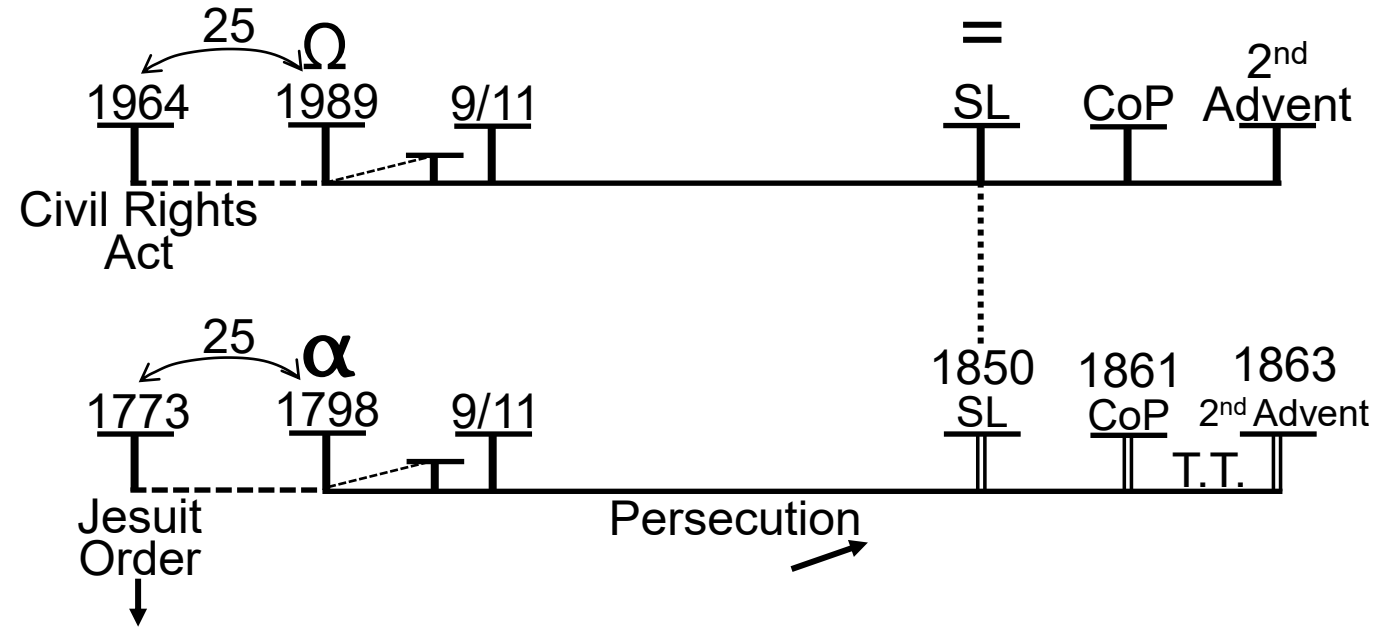

Our Alpha History

When it says discrimination on the basis of sex, what about those who identify as a different gender? What about those who are born attracted to someone of the same gender as themselves? Do they have the same civil rights as you and I? Who would say that we don't have that persuasion?

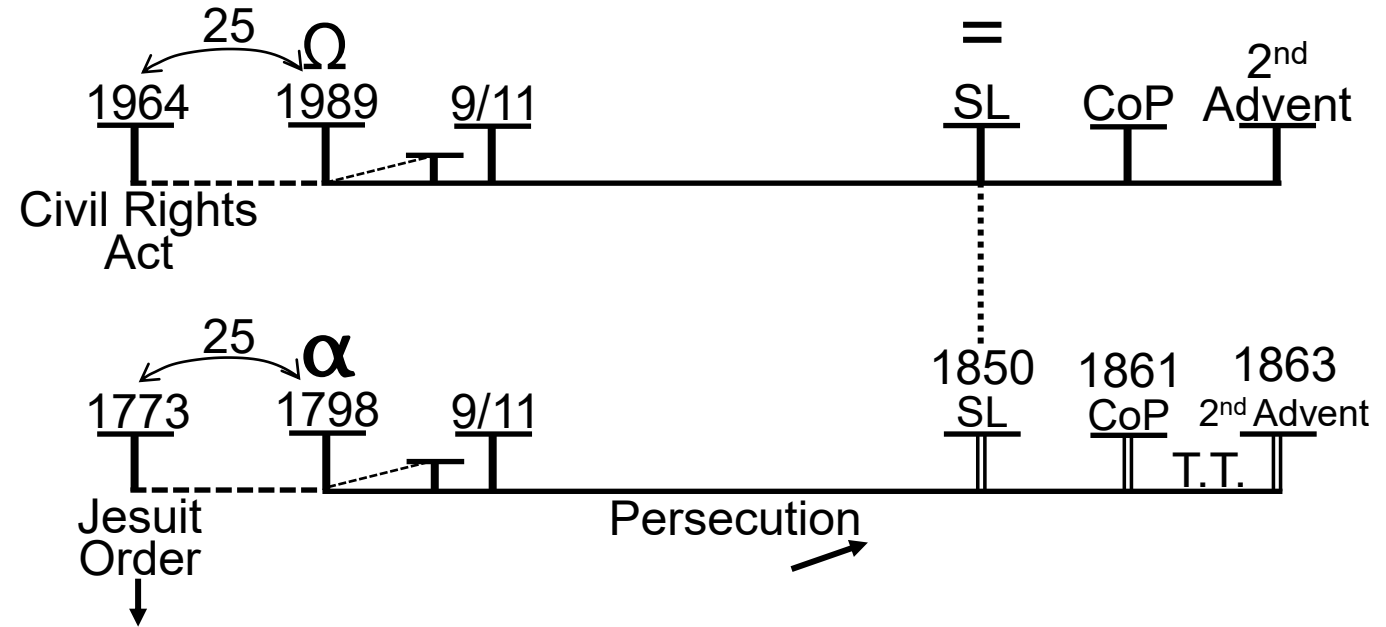

Our Alpha History

The debate is again, how do you read; how do you read the Constitution; how do you read the Declaration of Independence; how do you read the Civil Rights Act of 1964. And depending on how you read, determines who you consider has rights and who does not have rights.

Question: **Were we being persecuted actively between 1863 and 1989?**

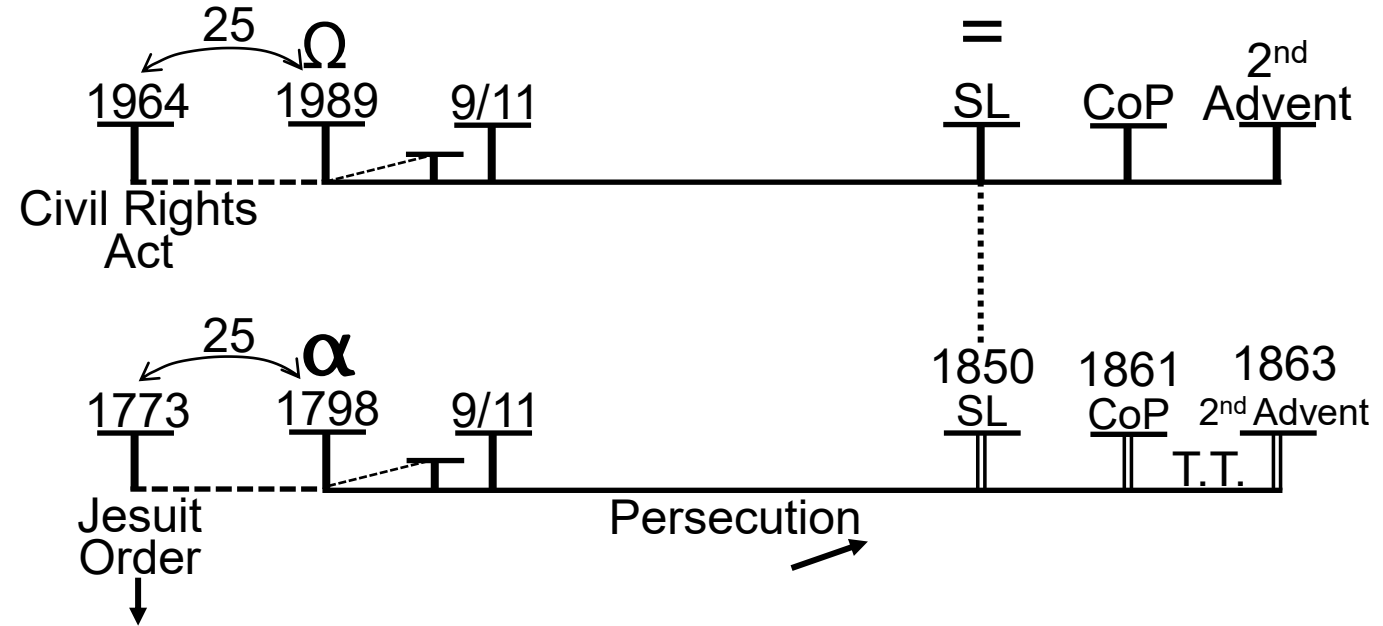

Our Alpha History

No.

You can see an application of that persecution as we take on the concepts of Babylon, as the Adventist church more and more loses its way, but the persecution was not directed at Adventists.

Question: **The persecution was directed at who?**

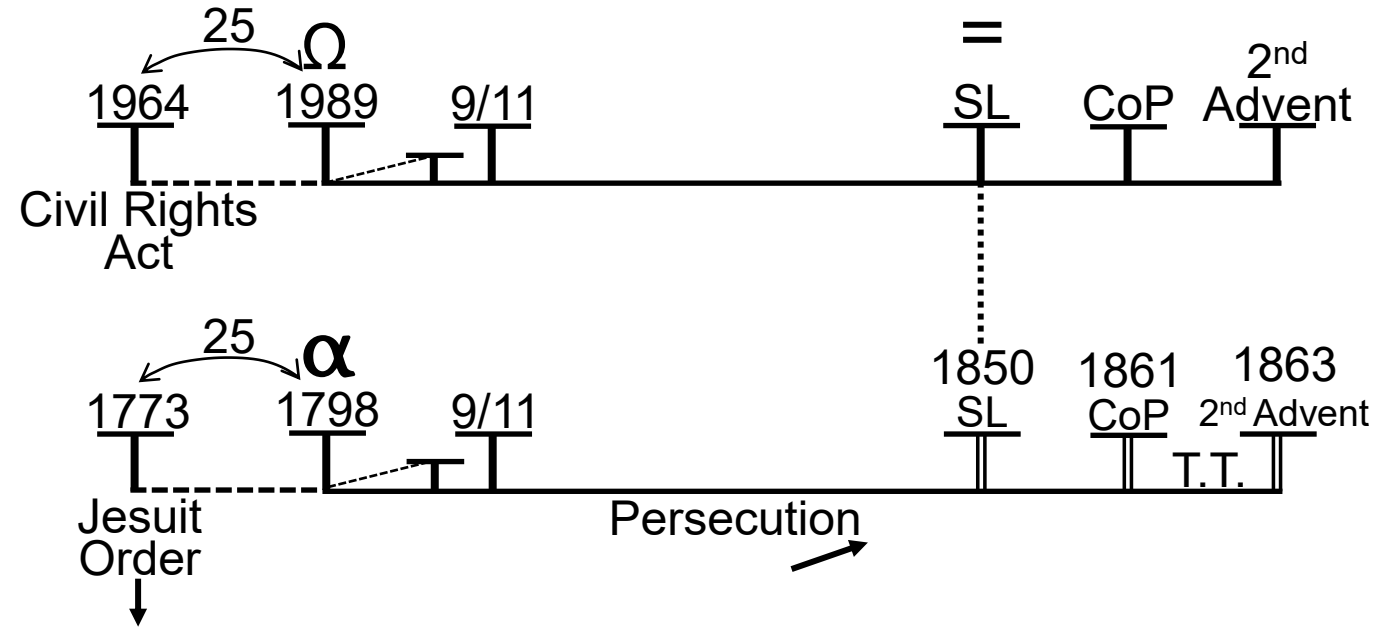

Our Alpha History

This was an issue of racism, nationalism.

Particularly in the context of the civil rights movement, its prior history dealing with the Ku Klux Klan, this is the issue of racism. It's the issue of nationalism. That's the context of the persecution that is being dealt with. There is also an inclusion in that of sexism, both sexism just in general and also sexism directed towards black women who were not given the right to vote in 1919-1920.

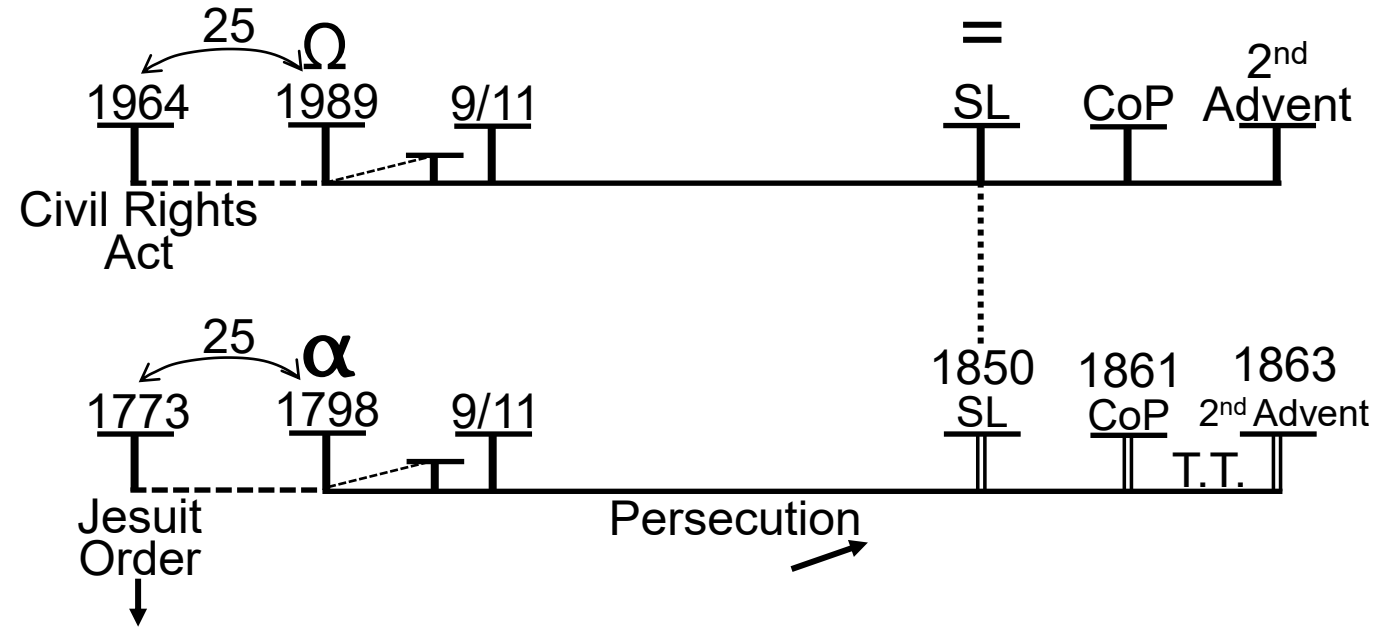

Our Alpha History

So, about 25 years before there is this Increase of Knowledge, you have this dying down of persecution.

And what do you know is going to happen?

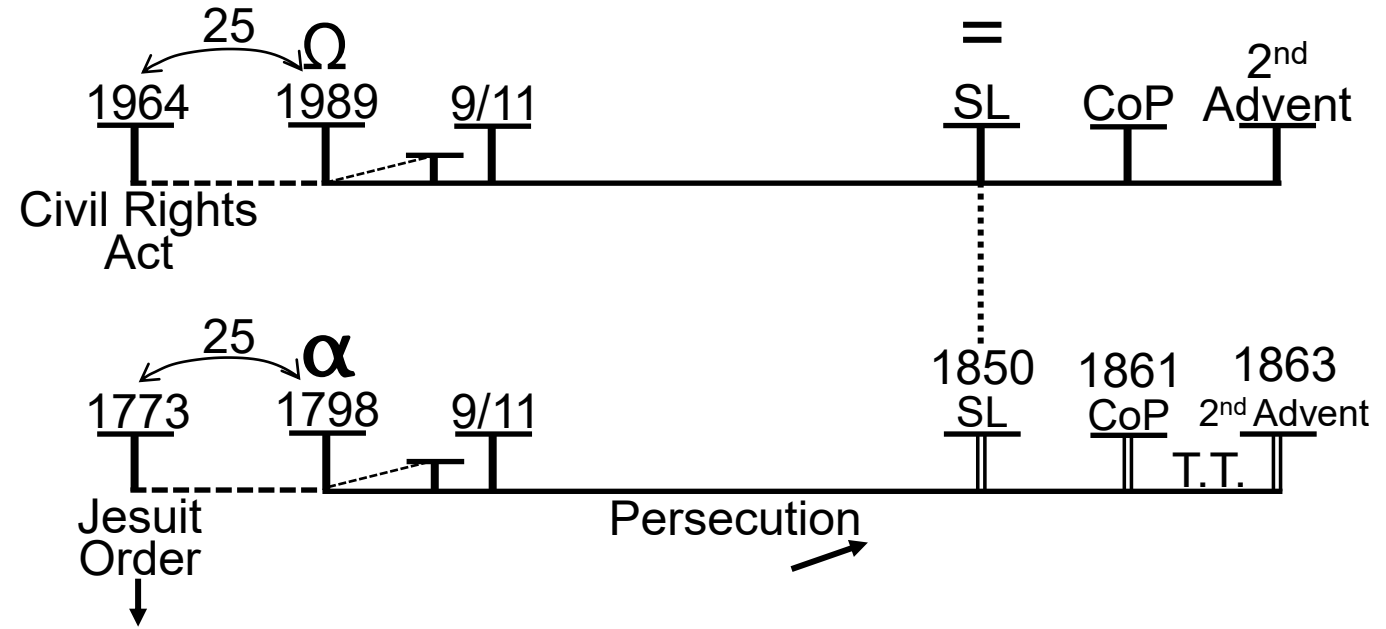

Our Alpha History

Persecution is going to rise up.

Ellen White's saying, they will be persecuted for their religious beliefs, because that is what died down and is coming back up.

But who was persecuted here in 1964?

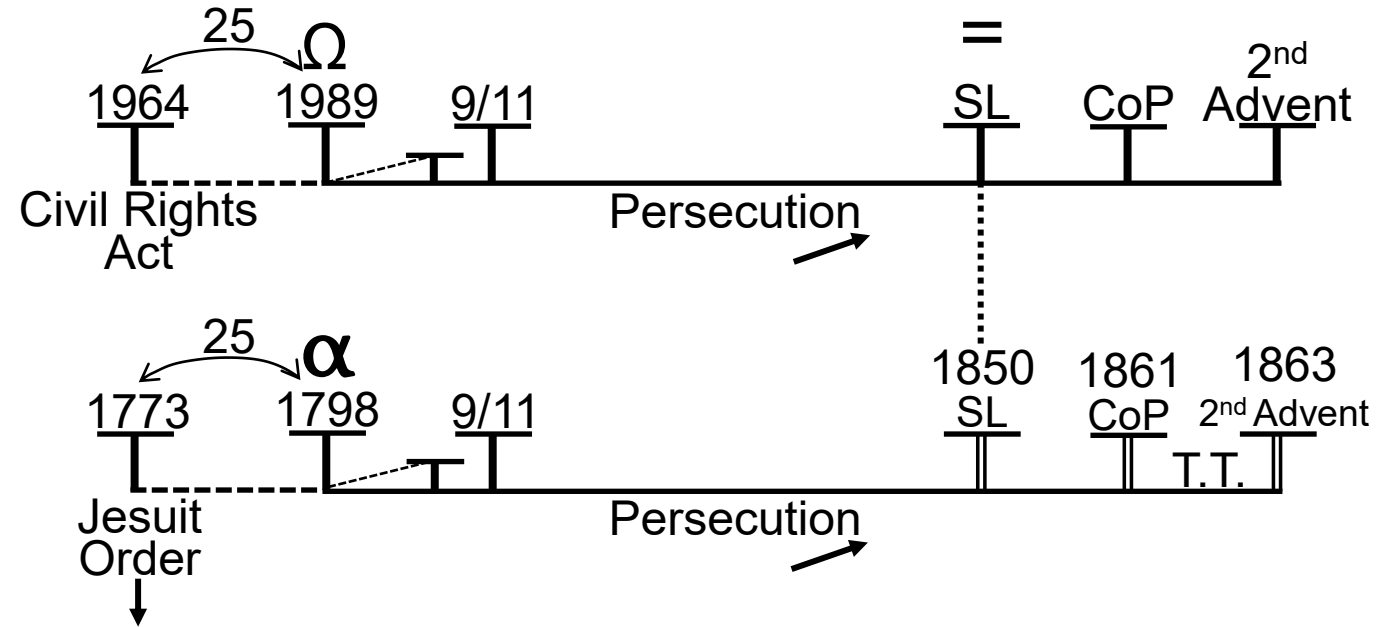

Our Alpha History

Minorities, yes.

This is where we have to stand like A.T Jones in Congress and say, I don't care whether this is a law enforcing Saturday and it makes my life easier or whether this is a law enforcing Sunday and it persecutes me; we stand for people's rights whether they directly affect us or whether they don't.

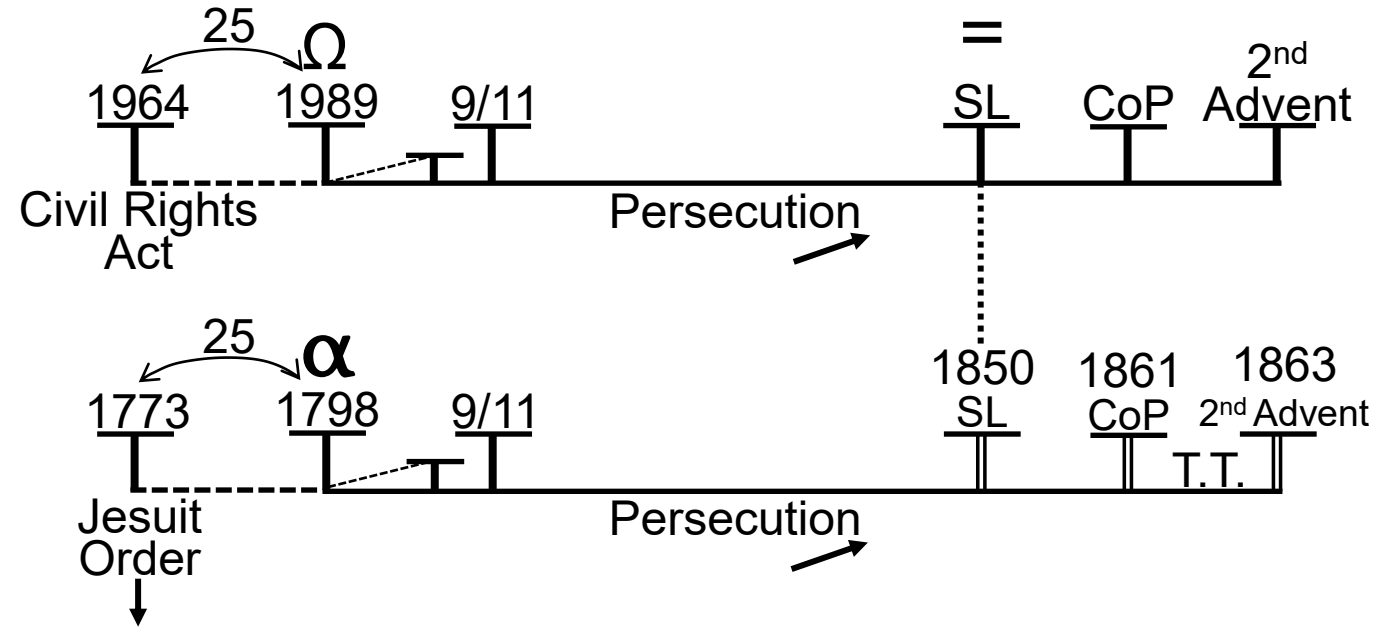

Our Alpha History

You can already start to see a compare, but also a contrast. And this persecution also happened largely under a church-state union, because **the south was defending slavery based on what book?**

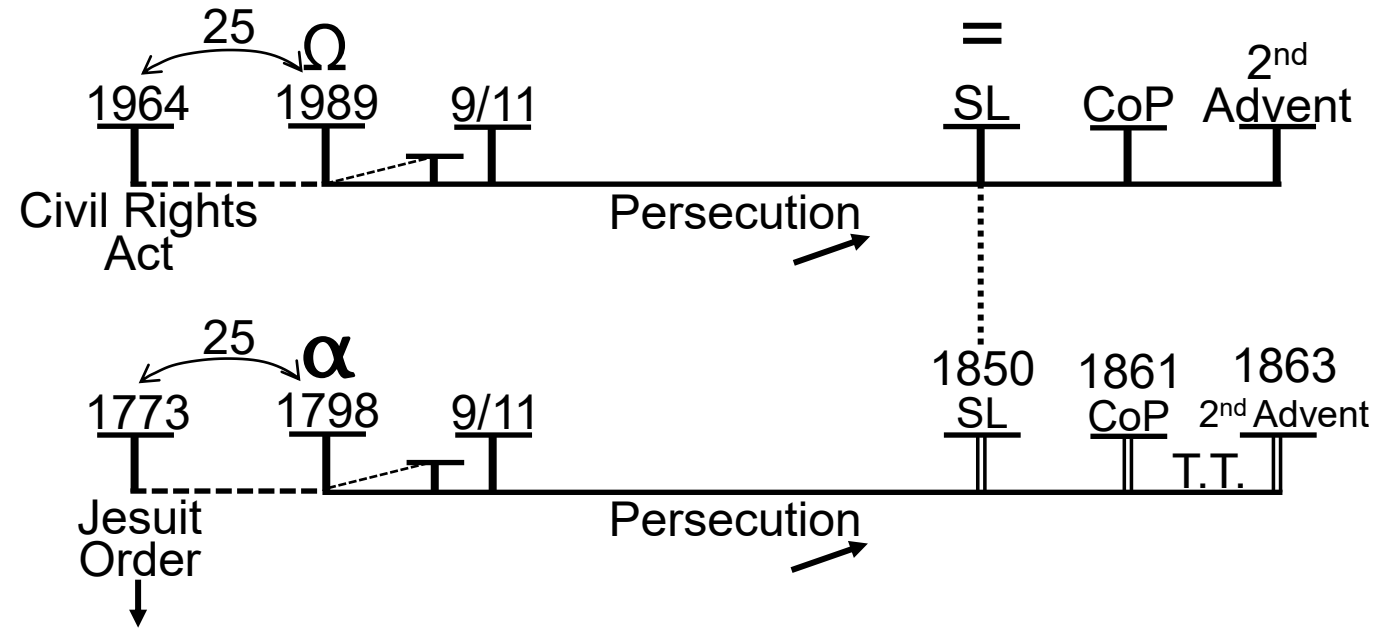

Our Alpha History

The Old Testament and portions of the New Testament. So, it was also a church-state argument and we've discussed that over the presentations gone before.

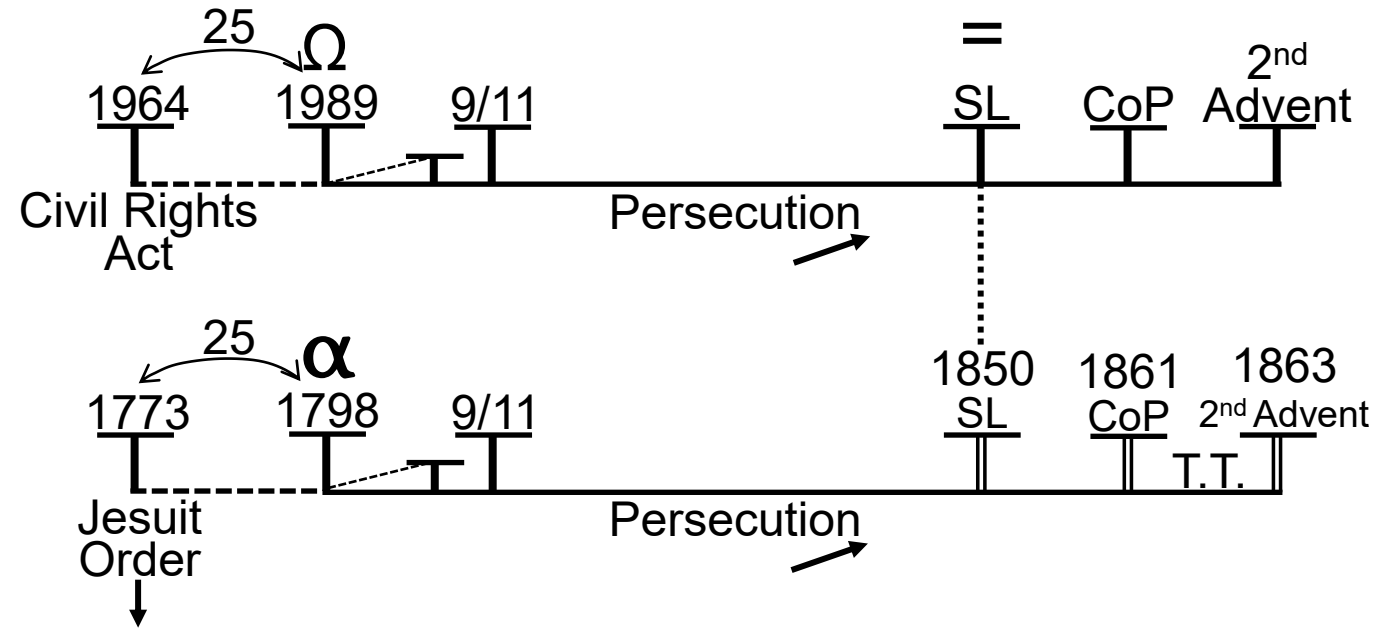

Our Alpha History

We are not repeating as much as we did last year. So, this presentation, for example, is unlikely to be repeated at another school or camp meeting by myself; someone else may do that, but it's not going to be done even by them with their thoughts at the level it has been in the past. So, we need to go back and watch, watch the German International camp meeting; go back to the prior presentations that we've already done that go into the split through Protestantism, Civil War and Protestantism. 1798 you have that split, you have that split in the Civil War, you have the split now. We talked about Mary Relfe. We talked about 1919 and the approach that a portion of Protestantism took at the very outset of globalism. But when it comes to this [Jesuit Order] argument, just like this [Civil Rights] one, it's a split through Protestantism.

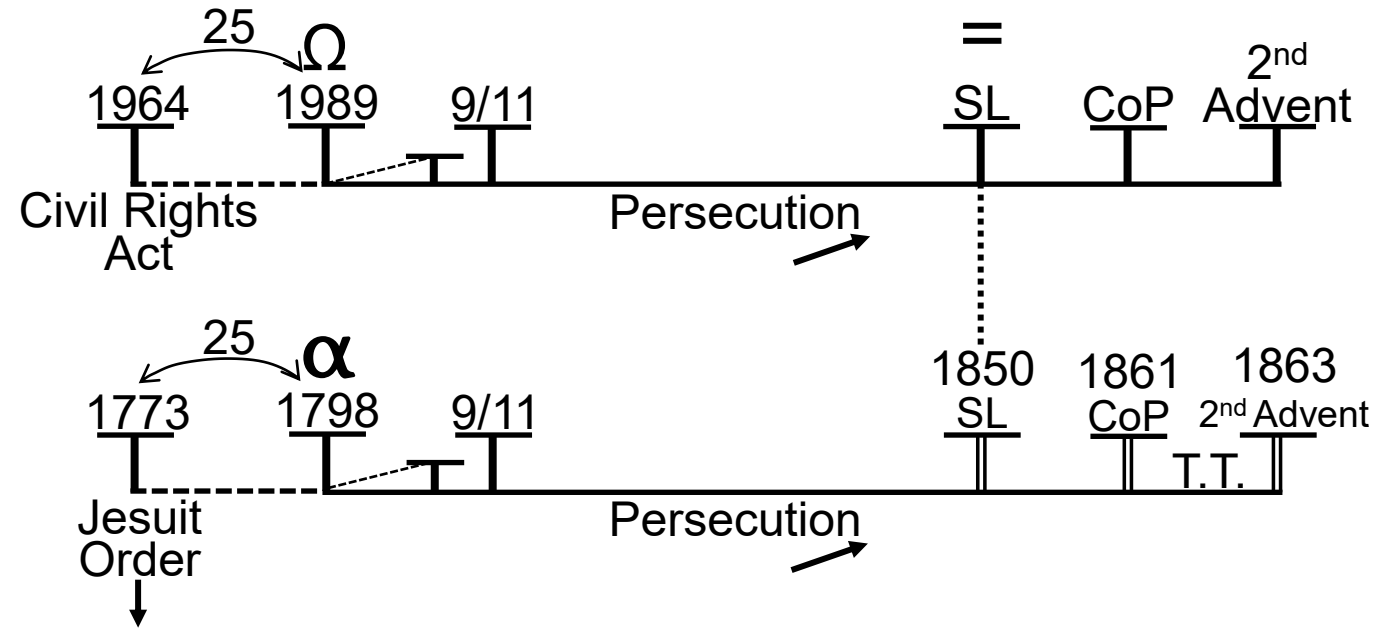

Our Alpha History

I just wanted to remind us of what we've already covered before. So, if Christ was to return here in 1863 (and this was why we went on one of our tangents), if was Christ was to return in 1863, what did the United States have to do?

Going back to our last two classes, what does the United States have to do?

Become a beast. That beast has to speak as a dragon. So, it's going to be a beast that speaks as a dragon. We looked at what that meant; what does it mean when it speaks as a dragon?

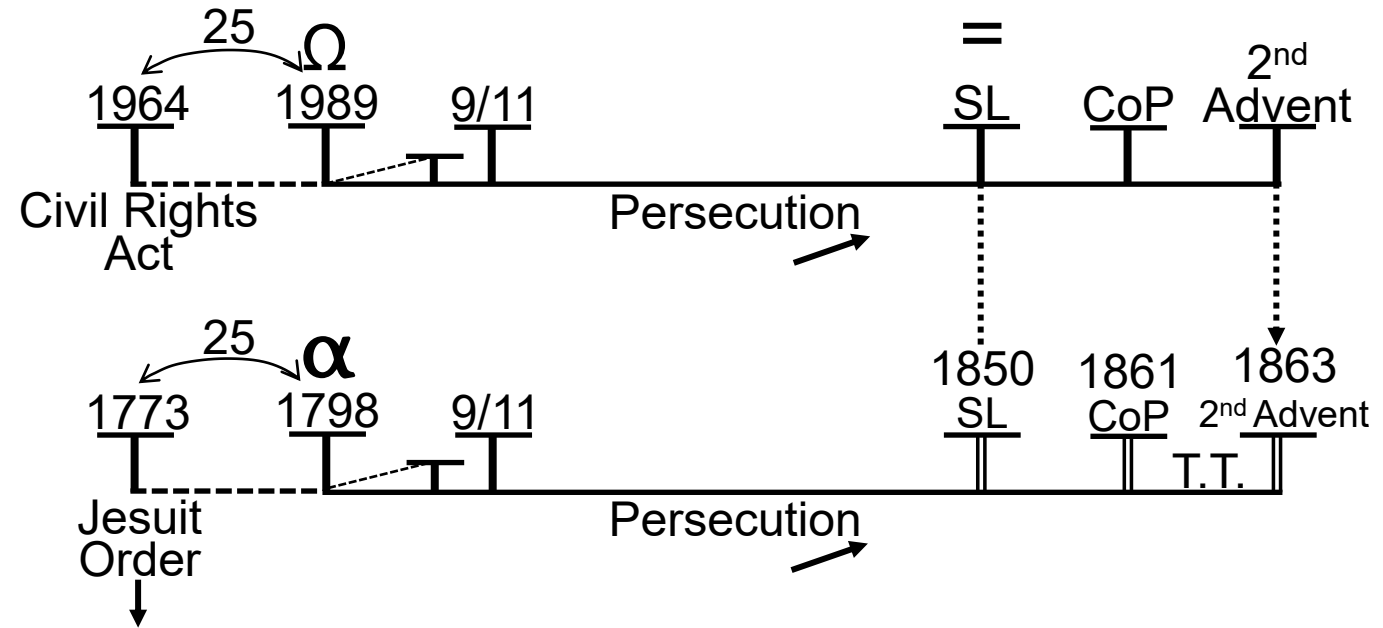

Our Alpha History

We looked at the three branches of government. It'll be the actions of the Legislative and the Judicial.

There has been some confusion caused, that I'm suggesting that we don't see anything in the Executive, and that's not what I'm saying. If Mitch McConnell wants to block Obama... Someone correct me if I get Mitch McConnell and Jeff Sessions mixed, always in my mind I can't even picture them differently; they feel like twins. Mitch McConnell is going to block Obama from appointing a Justice to the Supreme Court.

Question: Why is he doing that? Because he's waiting for a change; **in what branch of government?**

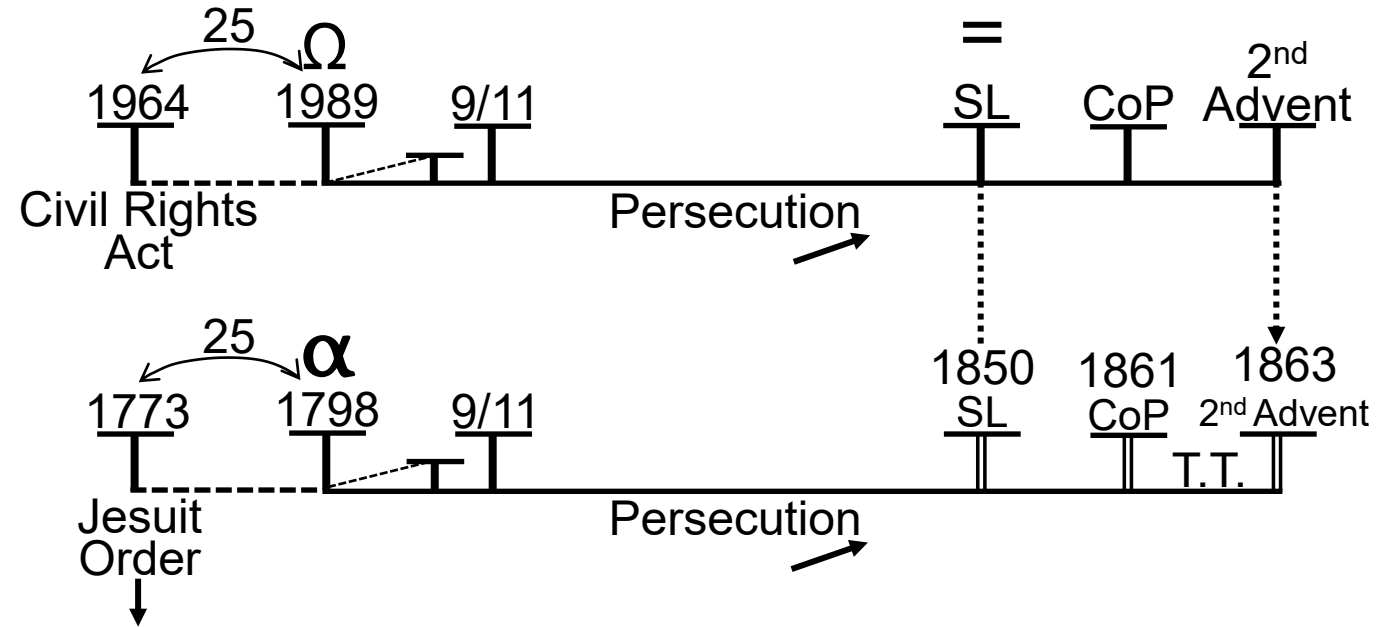

Our Alpha History

The Executive Branch. He needs the Executive Branch to manipulate and sway the Judicial. So, I'm not suggesting that there is no action of the Executive Branch necessary to do that. We need to see the actions of the Executive. But when it speaks, it's through the Legislative and the Judicial. And they're already arguing that Trump has appointed Judges to the Judicial Branch who are uncharacteristically young, and these are lifetime appointments.

Question: The changes Trump has made to the Judicial Branch, **can another president change them?**

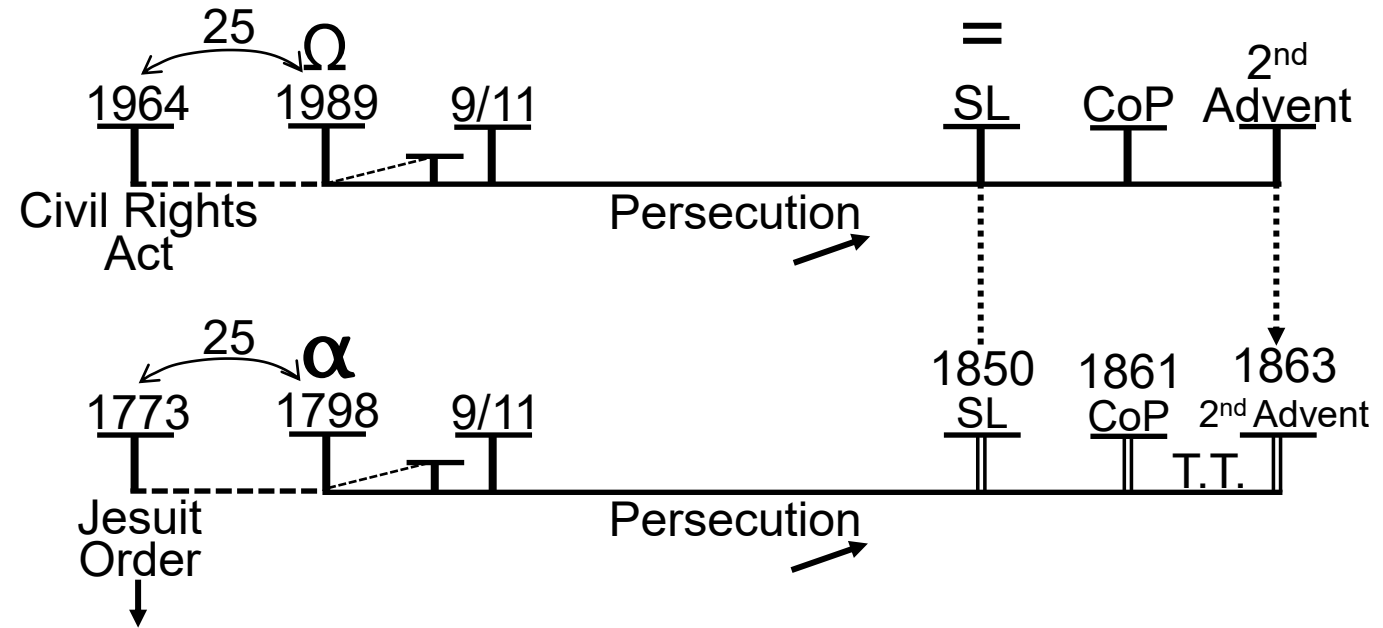

Our Alpha History

No. This is unchangeable for a generation; that's the extent to which these actions cannot be undone. And again, it began in 2014, as the lines tell you it would.

So, you need to see the United States speak as a dragon in the history prior to 1861, and we've already laid that out as being 1850 and the Fugitive Slave Act.

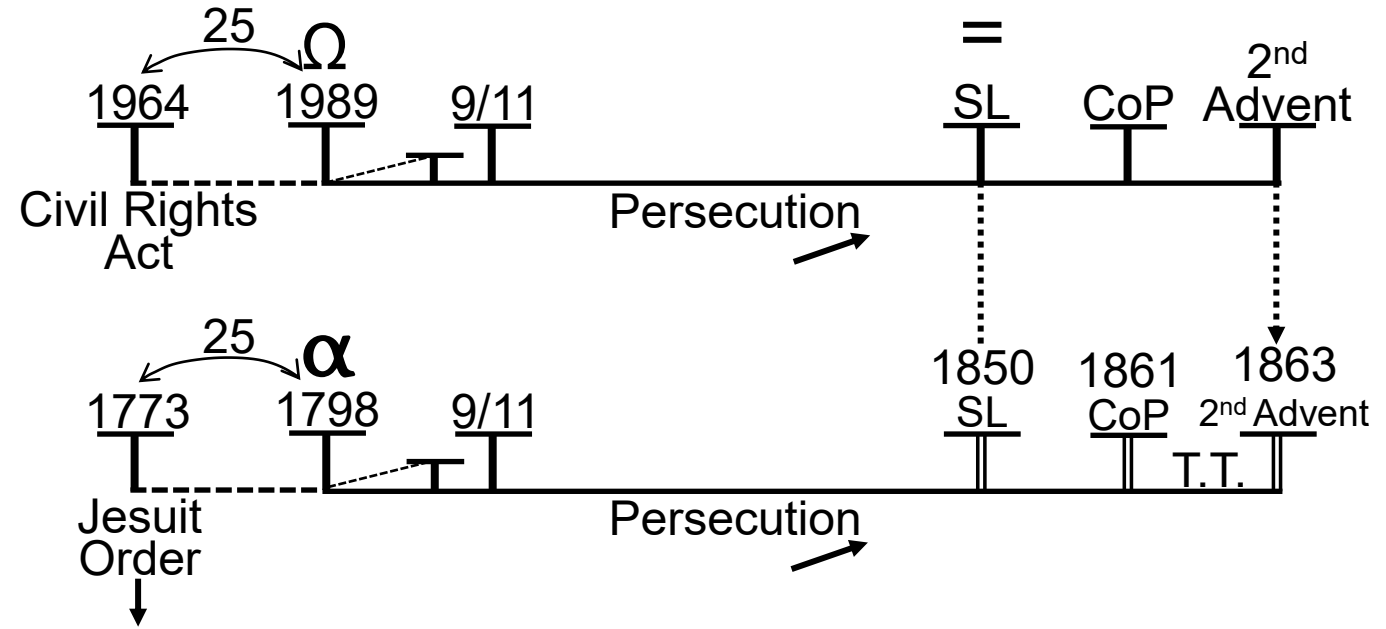

Our Alpha History

I want to give us a couple of quotes. These have been read before I'm sure, but just so everyone has them, Review and Herald August 27, 1861 paragraph 4. These would be quotes from the German camp meeting too. We will read J.N. Andrews 1855. I just want to read the perspective they had of the 1850 Compromise. It's 108.1; it just squeezes in there. 1842 William Miller 227.2. And I'm not going to read a lot from these, so don't panic. And Testimonies Volume one 201.1.

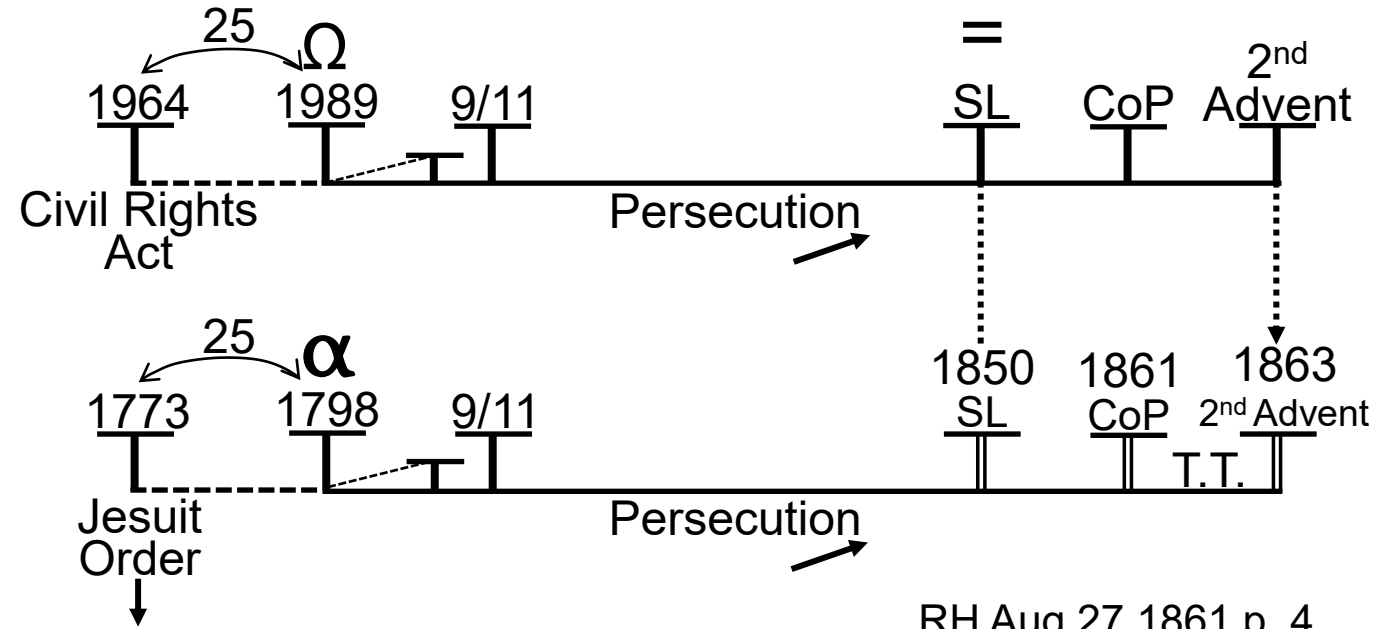

RH Aug 27 1861 p. 4
 1855 JNA TAR 108.1
 1842 WiM MWV2 227.2
 1T 201.2

Our Alpha History

This is 1861 Review and Herald:

“At the Roosevelt conference, when the brethren and sisters were assembled on the day set apart for humiliation, fasting and prayer, Sabbath Aug. 3, the Spirit of the Lord rested upon us...” {RH, August 27, 1861 par. 4}

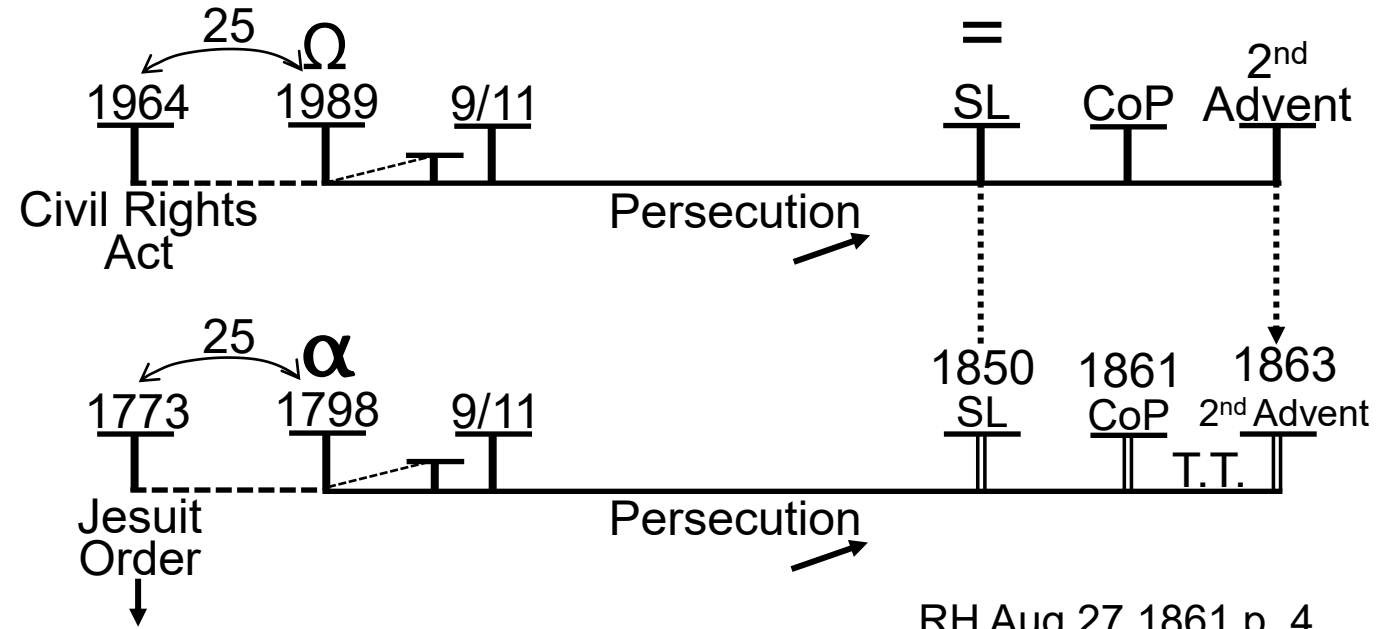

RH Aug 27 1861 p. 4
1855 JNA TAR 108.1
1842 WiM MWV2 227.2
1T 201.2

Our Alpha History

So, this is August 3, 1861 that she has this vision. This is the beginning history of the Civil War. Ellen White has taken off in vision and shown the sin of slavery.

“Slavery has long been a curse to this nation. The fugitive slave law was calculated to crush out of man every noble, generous feeling of sympathy, that should arise in his heart for the oppressed and suffering slave. It was in direct opposition to the teaching of Christ.”
 {RH, August 27, 1861 par. 4}

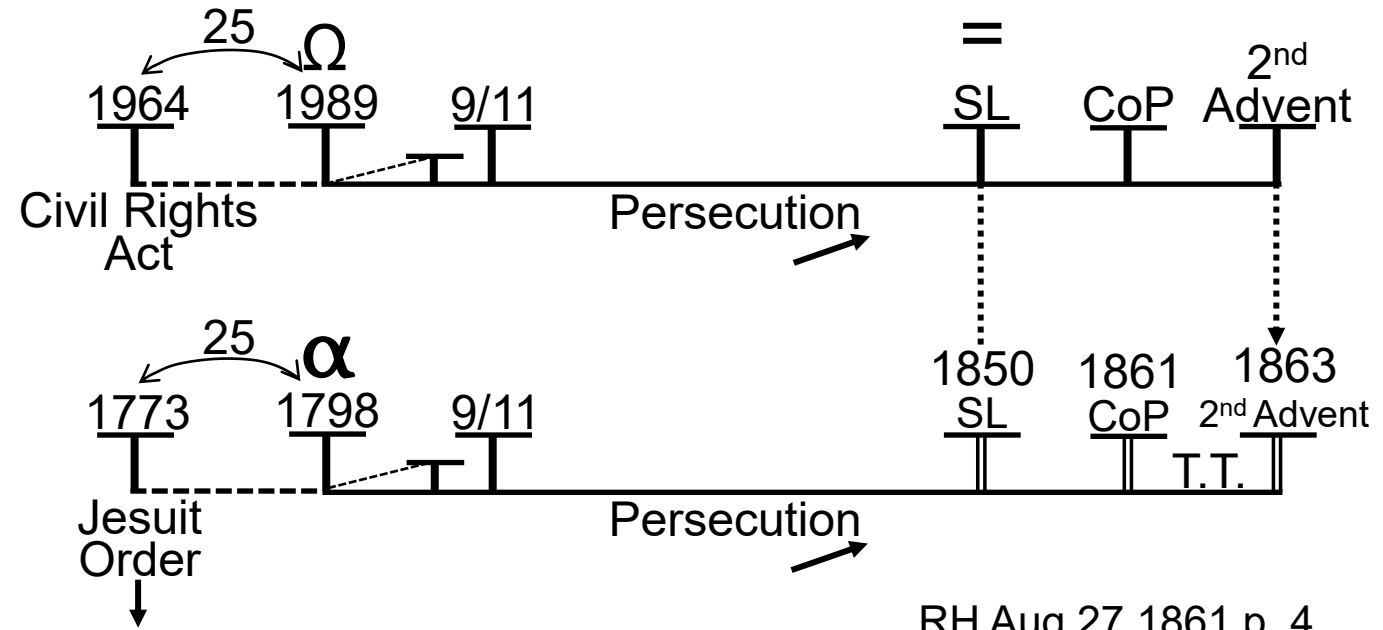

RH Aug 27 1861 p. 4
 1855 JNA TAR 108.1
 1842 WiM MWV2 227.2
 1T 201.2

Our Alpha History

When she says, it's in direct opposition to the teaching of Christ, if you keep that law, what are you doing? You're violating the law of God. So, what they have done is institute a law, that to keep, would require you to trample on the law of God. Does that make sense? And you can keep it in the forehead or in the hand.

“God's scourge now is upon the North, that they have so long submitted to the advances of the slave power. The sin of Northern proslavery men is great. They have strengthened the South in their sin...” {RH, August 27, 1861 par. 4}

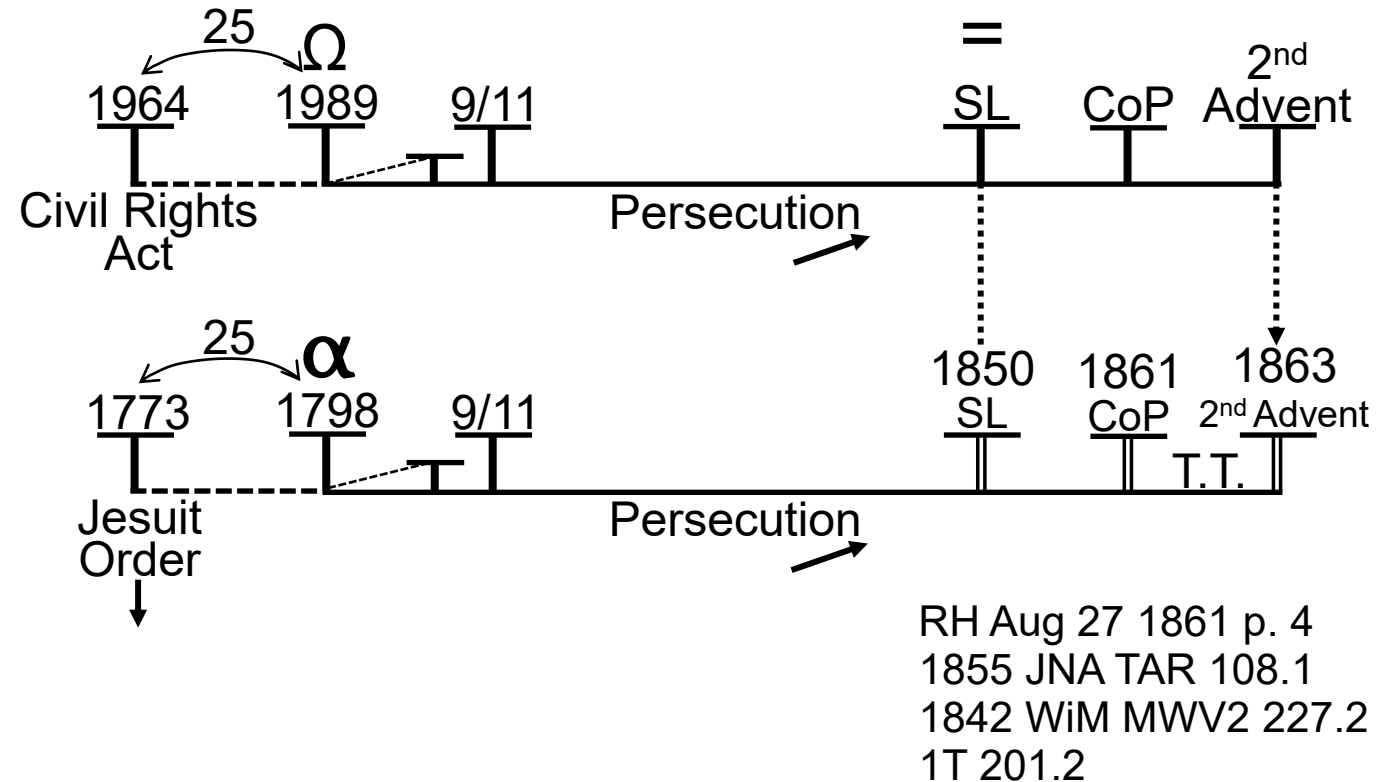

Our Alpha History

This compromise, did it **just** occur in 1850? No. This is a series of compromises that the North has been making over the last decades, over the last half century. These are long-standing compromises that have built up to the 1850 compromise. And I want to make the argument, from the very beginning, that where they compromised more than anywhere else leading up to 1850 was in their elections. They compromised in choosing their candidates for election. Because when they wanted to choose a candidate who particularly represented the North, they also wanted him to win. So, would they choose one of those extremist abolitionists, or would they look for a nice-looking centrist? They kept going for the centrist, and the centrist was not considered radical. And to be radical would be to be an abolitionist. So, as we discuss more of the political history of that time, I just want us to consider that thought.

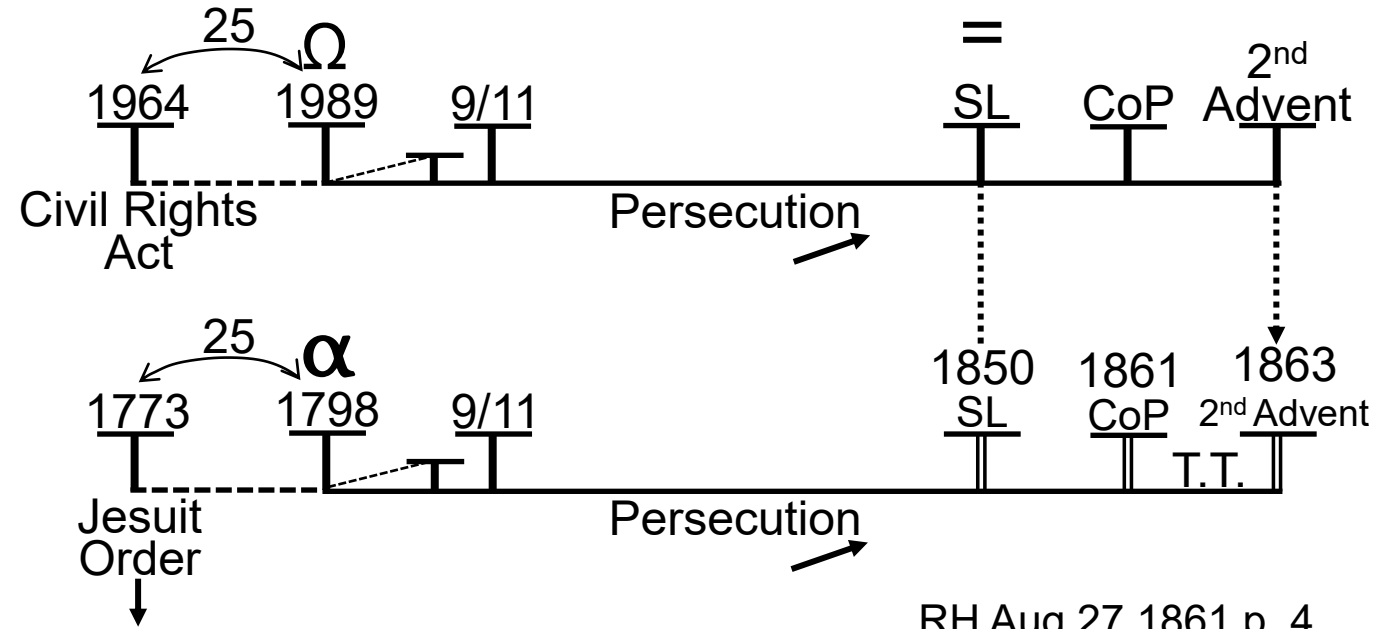

RH Aug 27 1861 p. 4
1855 JNA TAR 108.1
1842 WiM MWV2 227.2
1T 201.2

Our Alpha History

This is J.N. Andrews 1855. He's referring to Matthew 23, the pharisees.

*“They say that **had** they lived in the days of their fathers, they would not have been partakers with them in the blood of the prophets. But when their ‘hour and the power of darkness’ came upon them, how completely did it show them under the power of Satan! The downward course of our own nation on the subject of African slavery, is a fearful warning of the abyss into which it is about to plunge.” {1855 JNA, TAR 108.1}*

JNA, TAR = John Nevins Andrews,
The Three Angels of Revelation 14:6-12

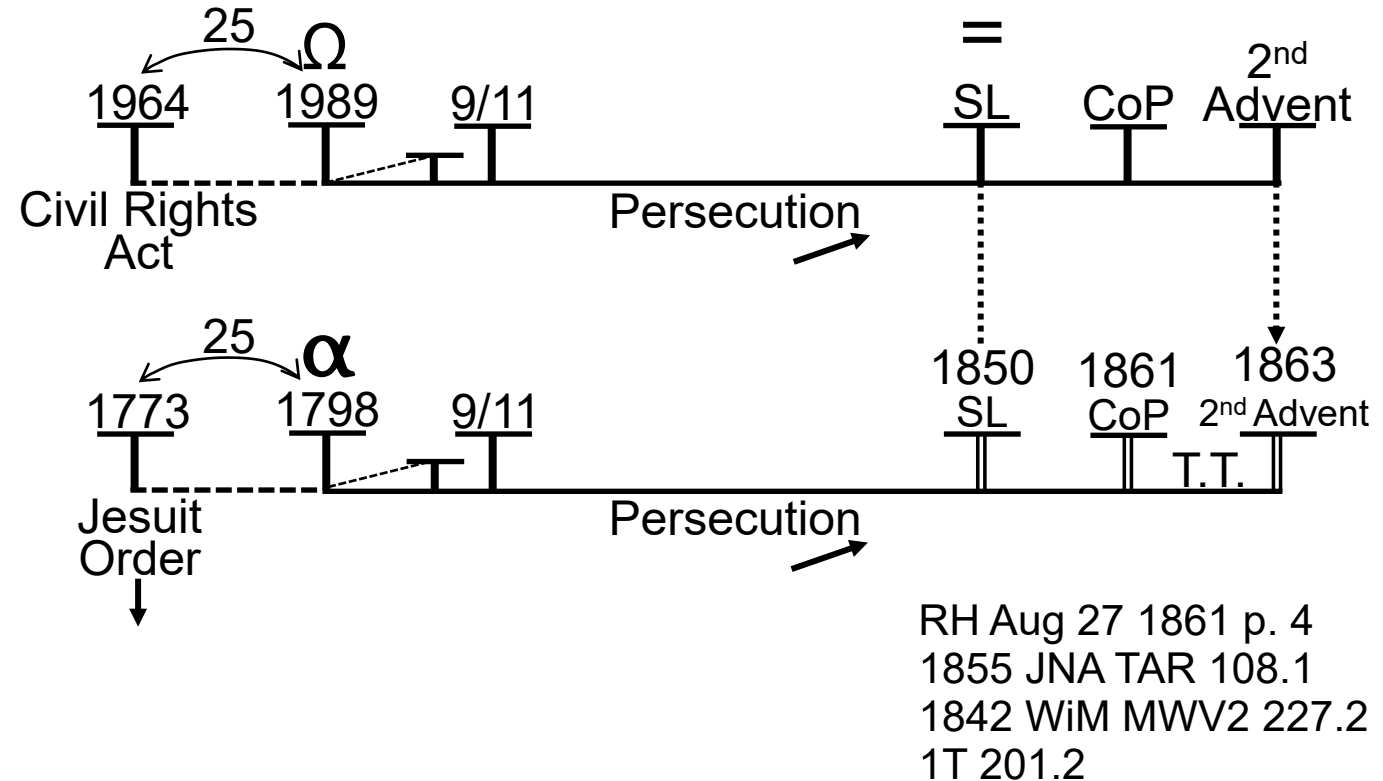

Our Alpha History

This is written in 1855 before the Civil War.

“The most infamous law of the nineteenth century is the ‘fugitive slave law.’” {1855 JNA, TAR 108.1}

William Miller, 1842.

“All these powers have pretended to work miracles, to establish their authority over the bodies and souls of men. But what are the principles which each of these teach their political followers? The dragon and his political party, in whatever nation they may appear, will support tyranny, slavery, and aggrandizement of the few at the expense of the many.” {1842 WiM, MWV2 227.2}

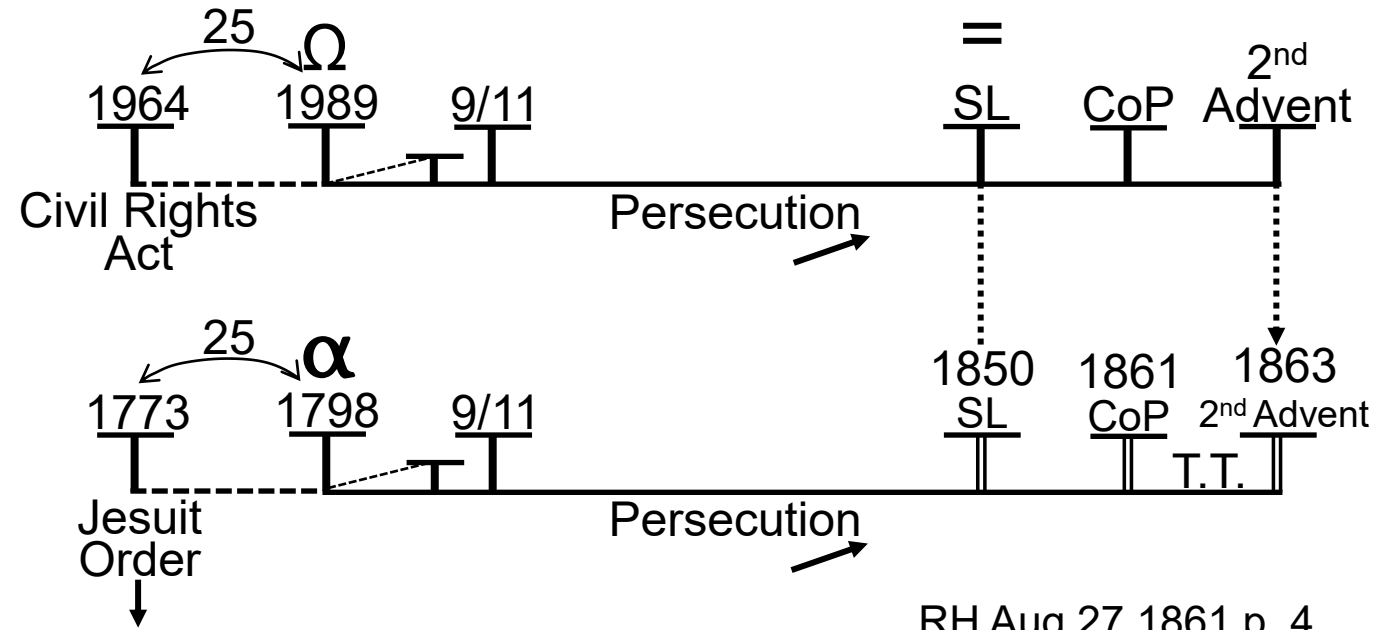

RH Aug 27 1861 p. 4
 1855 JNA TAR 108.1
 1842 WiM MWV2 227.2
 1T 201.2

WiM, MWV2 = William Miller,
 Miller's Works. Volume 2.

Our Alpha History

What is William Miller saying you need to look for?

What's the spirit of the 1260? What should you expect to see when that spirit rises again?

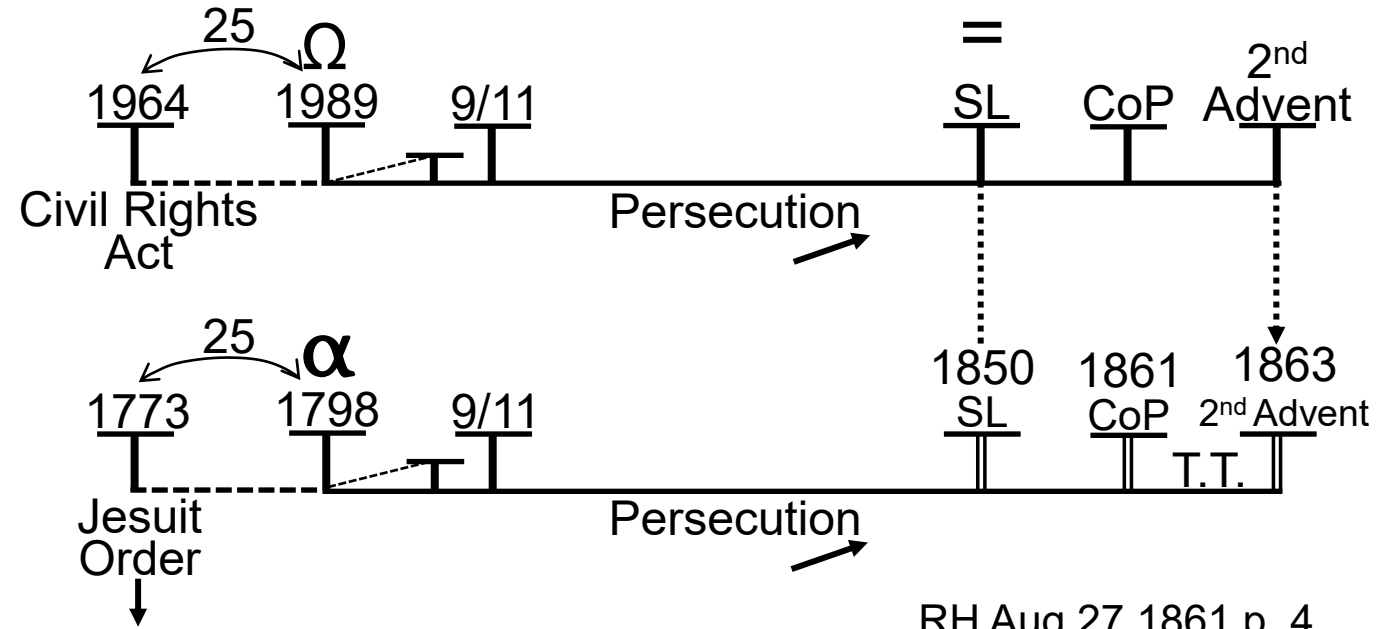

RH Aug 27 1861 p. 4
1855 JNA TAR 108.1
1842 WiM MWV2 227.2
1T 201.2

Our Alpha History

They will support the tyranny, slavery, and aggrandizement of the few, of the minority, at the expense of the powerful majority. The moral majority. They will try to establish their authority over the bodies and the souls of men. So, even William Miller is recognizing slavery and the impact of equality on what you would expect these powers to look like.

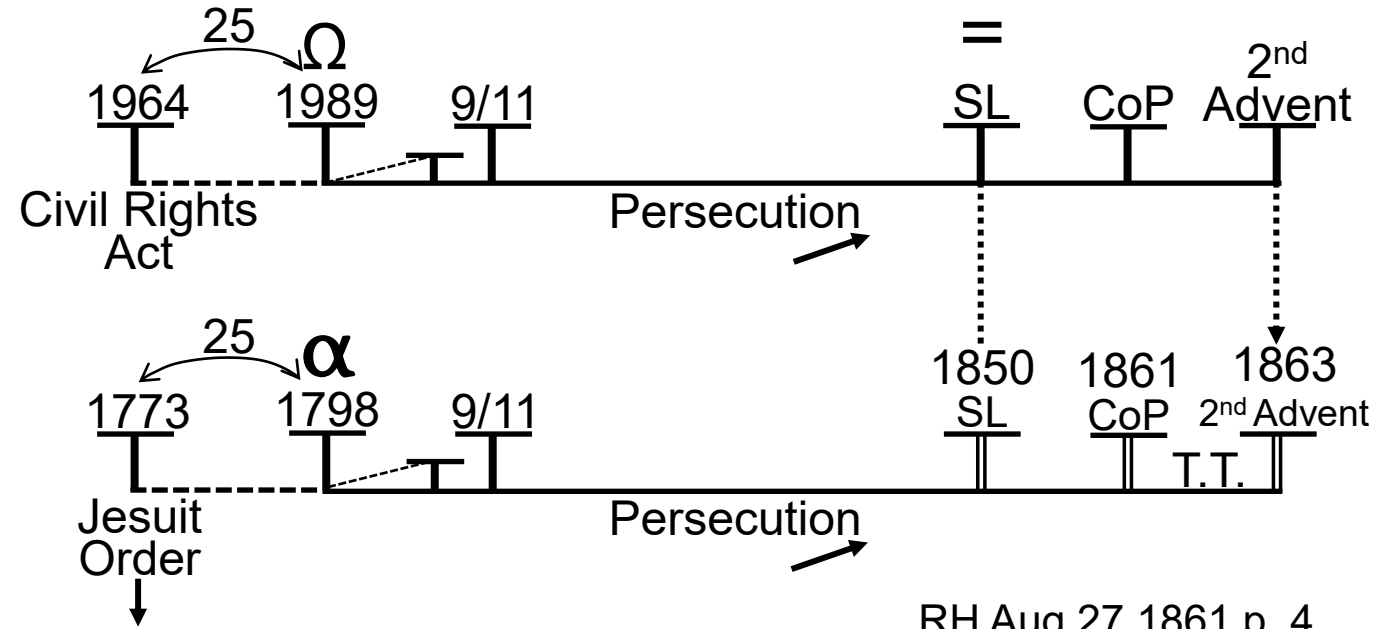

RH Aug 27 1861 p. 4
1855 JNA TAR 108.1
1842 WiM MWV2 227.2
1T 201.2

Our Alpha History

Going back to 1 Testimony, Ellen White.

“We have men placed over us for rulers, and laws to govern the people. Were it not for these laws, the condition of the world would be worse than it is now.” {1T 201.2}

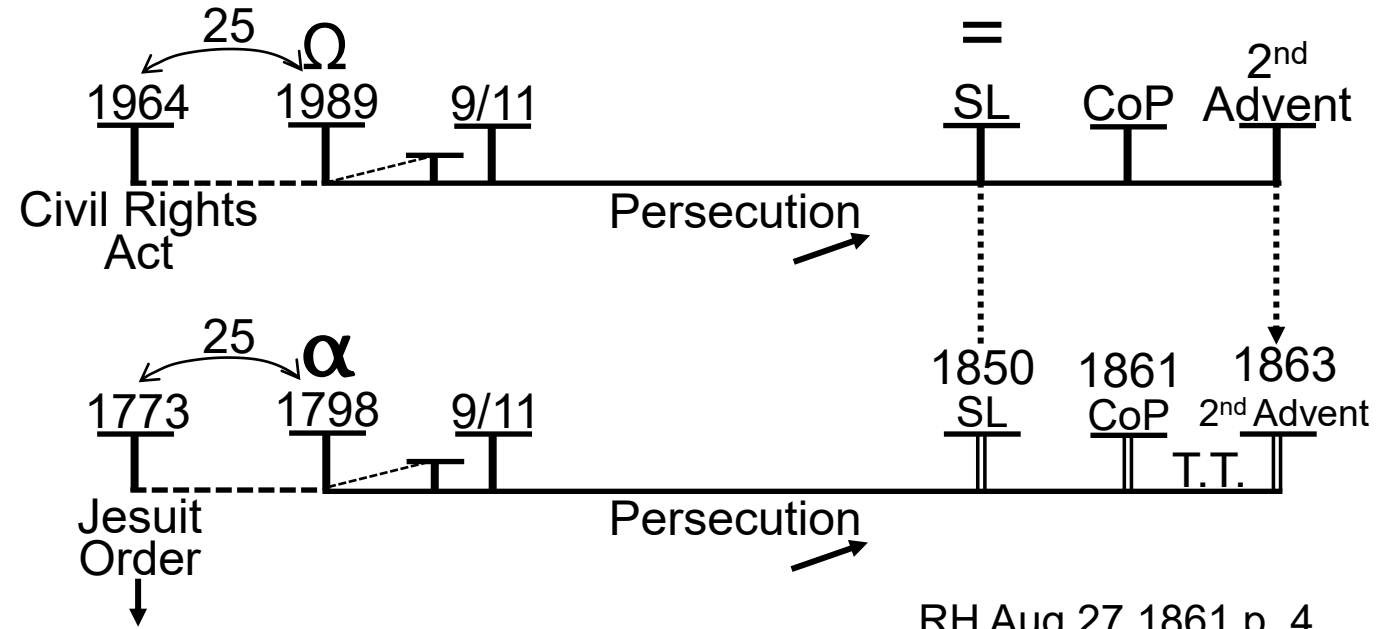

RH Aug 27 1861 p. 4
1855 JNA TAR 108.1
1842 WiM MWV2 227.2
1T 201.2

Our Alpha History

So, this idea of freedom, does it call for a lack of law or a lack of government? No. The issue is:

“Some of these laws are good, others are bad. The bad have been increasing, and we are yet to be brought into straight places. But God will sustain His people in being firm and living up to the principles of His word. When the laws of men conflict with the word and law of God, we are to obey the latter, whatever the consequences may be. The law of our land requiring us to deliver a slave to his master, we are not to obey; and we must abide the consequences of violating this law.”
{1T 201.2}

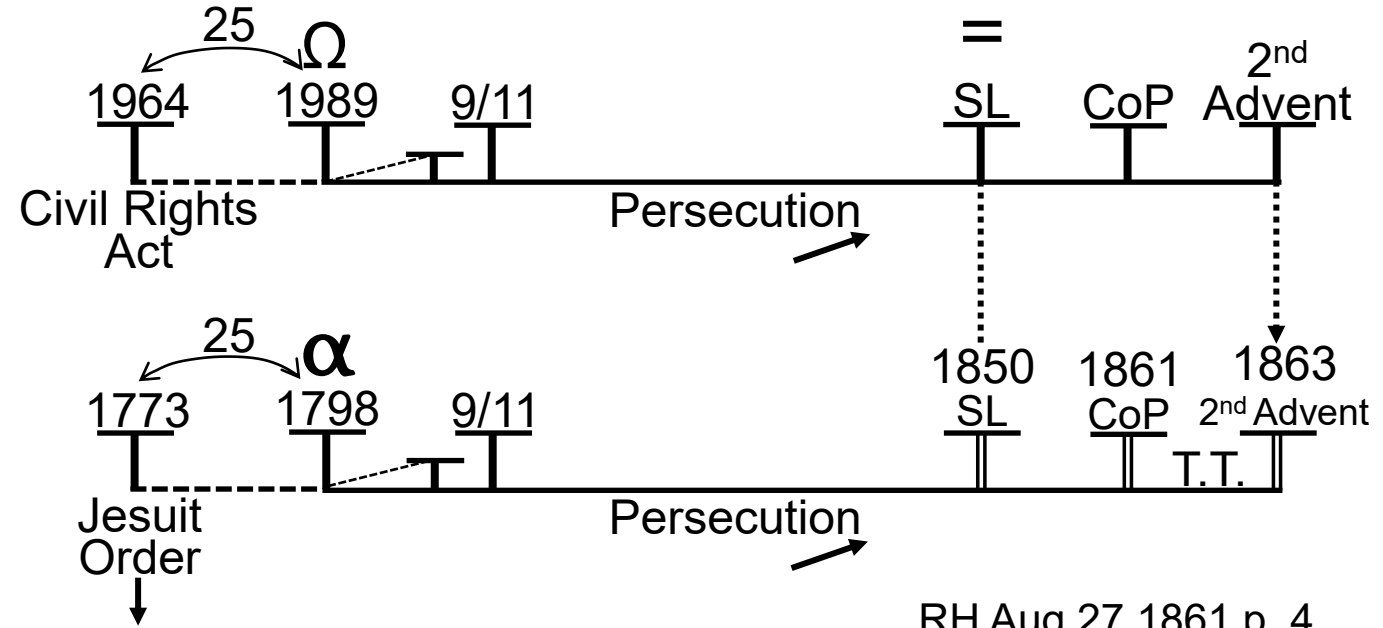

RH Aug 27 1861 p. 4
1855 JNA TAR 108.1
1842 WiM MWV2 227.2
1T 201.2

Our Alpha History

So, this is going back to the first quote we made (RH 1861). It's "in direct opposition to the teaching of Christ." So, when we come to the Great Controversy definition of the Sunday Law, what is the problem with the Sunday Law?

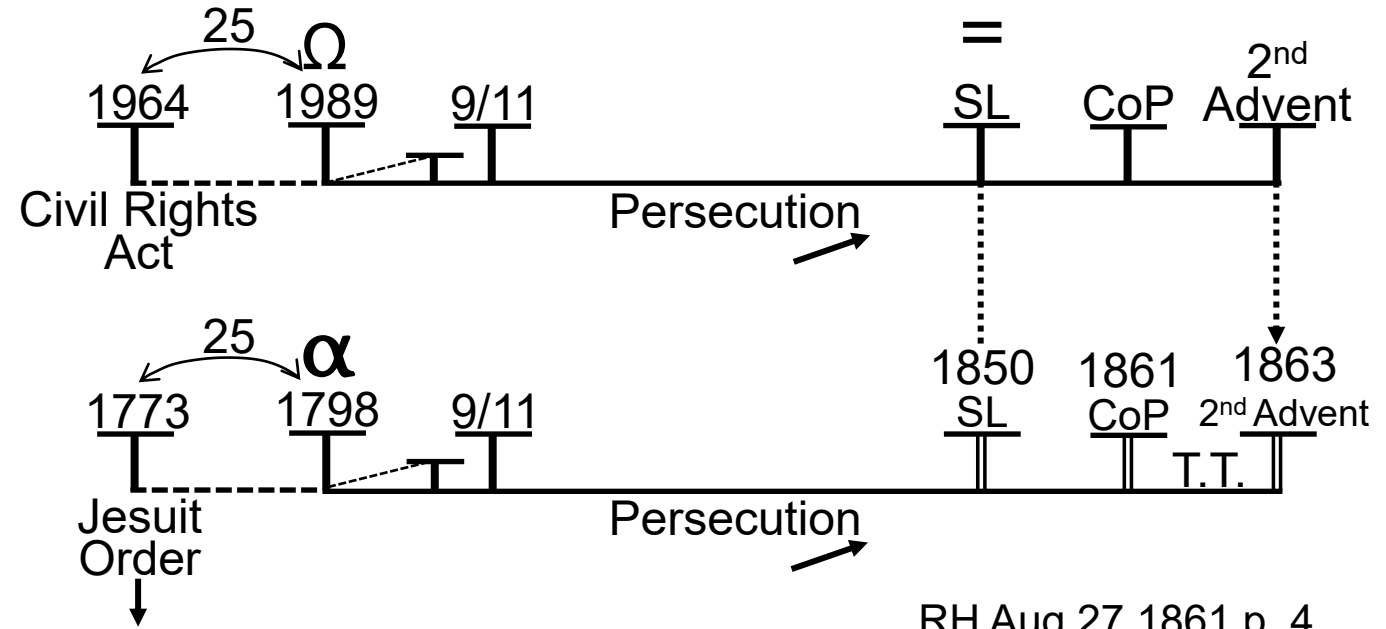

RH Aug 27 1861 p. 4
1855 JNA TAR 108.1
1842 WiM MWV2 227.2
1T 201.2

Our Alpha History

It requires us to trample on the law of God. What was it about the 1850 Compromise which made it the most infamous of the nineteenth century?

It required you to trample on the law of God.

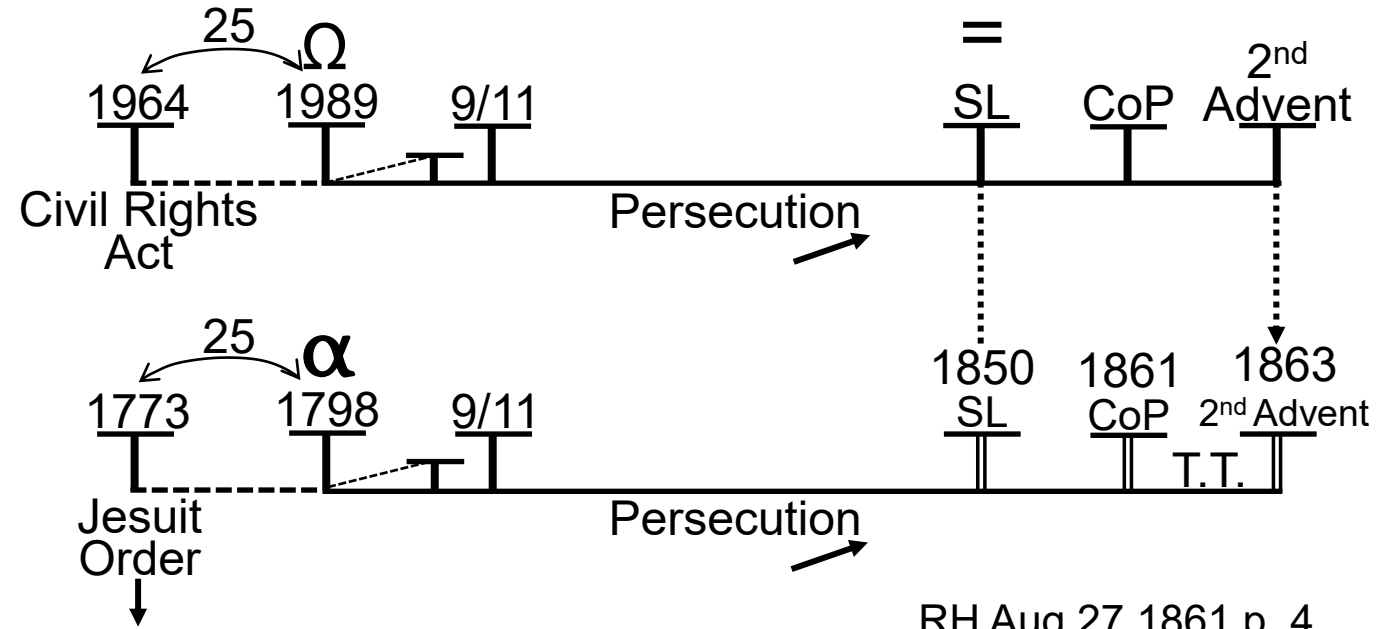

RH Aug 27 1861 p. 4
1855 JNA TAR 108.1
1842 WiM MWV2 227.2
1T 201.2

Our Alpha History

Now you had to violate the laws of the land. So, this is the 1850 compromise; it lines up with the Sunday Law waymark. And it is as you would expect found in Early Writings, Spiritual Gifts Vol 1. That is the whole context of that first document, where she covers earth's history from Eden to the Second Advent. And she centers the sins of Babylon on this issue right here at 1850, because that is where you see in William Miller's words, the tyranny, the work of that beast power to control the bodies and the souls of men. But now enforcing, trying to enforce people, against their conscience, to participate in the same.

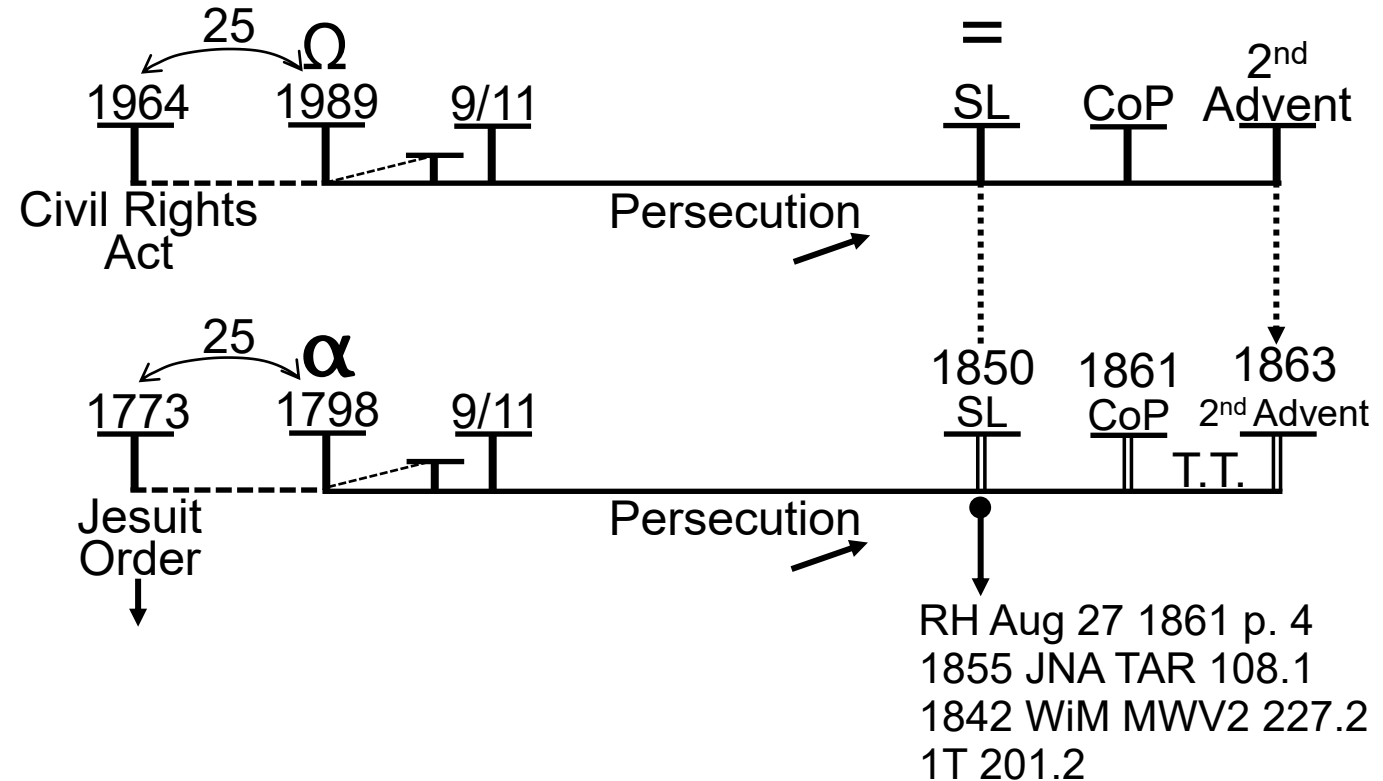

Summary

I'll close here for time. Next presentation we want to delve more into the structure and start having an overview of the external events found in this structure. So, just to summarize to close. We have looked at all of the movements God has operated with to spread the message of His kingdom over the last two thousand years plus. You have the End of Ancient Israel; it's a movement. It arises in exactly the time necessary, when you have this Roman peace, this special 200-year time period, which is able to encapsulate the growth and spreading of the gospel, the work of John the Baptist, Christ and His disciples, and the work of Paul. You had the Roman roads, peace on land and sea.

- End of Ancient Israel) • Pax Romano
4 BC) • Roads - Communication
- Protestant Reformation) • Printing Press
1518) • Communication
- Beginning of Modern Israel) • Trains/Steamboats/Telegraph
1798) • Communication
- End of Modern Israel) • WWW
1989) • Communication

Summary

Then you have the Protestant Reformation. That happens right on time as the printing press is able to be used to its fullest extent. And you have that method of communication give life to the Protestant Reformation right on time.

You have the technological revolution of the early 1800s, which happens right on time. December 1830 the train system, but before that, steamboats, and also the telegraph. Right on time for the spreading of the Millerite message. And it booms between 1850 and 1860; it booms by more than three times in this time period of 1850-1861, because that is when the gospel is to go to the world.

- End of Ancient Israel) •Pax Romano
4 BC) •Roads - Communication
- Protestant Reformation) •Printing Press
1518) •Communication
- Beginning of Modern Israel) •Trains/Steamboats/Telegraph
1798) •Communication
- End of Modern Israel) •WWW
1989) •Communication

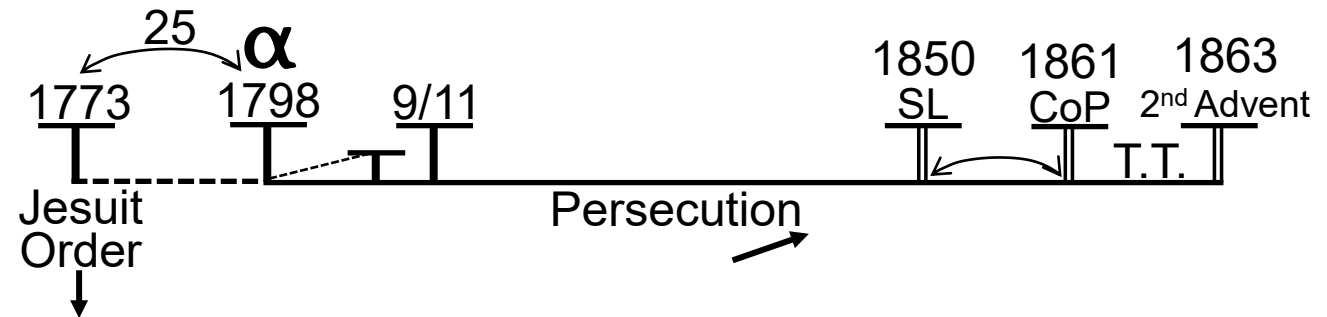

Summary

We spoke about the Midnight Cry message after Exeter, but even before that how it spread on rail cars and steamboats. Then we talked about our own history. One of the evidences that God has raised up a movement to communicate a message is the technological revolution itself of the information age in the World Wide Web.

We spoke that there is no light, there is no life outside of this Movement. It should make sense to us, for every other movement, and we have the testimony of three. The reason the Protestant Reformation did not become God's church in the sense of Ancient or Modern Israel is because of their own failures. It also wasn't the time frame. It did its work, a necessary work, of preparation.

- End of Ancient Israel) •Pax Romano
4 BC) •Roads - Communication
- Protestant Reformation) •Printing Press
1518) •Communication
- Beginning of Modern Israel) •Trains/Steamboats/Telegraph
1798) •Communication
- End of Modern Israel) •WWW
1989) •Communication

Summary

But they mixed, held on to so many Catholic ideas. You can't mix the message of a Pharisee with the parables of Christ. You cannot mix the Catholicism with Martin Luther; and he did that himself. You cannot mix the Protestant teachers of the day with the message of William Miller and Ellen White. You cannot mix Adventist pastors today, after the veil has already been torn, and expect them to give light to this Movement. That's not how God teaches us.

- End of Ancient Israel) • Pax Romano
4 BC) • Roads - Communication
- Protestant Reformation) • Printing Press
1518) • Communication
- Beginning of Modern Israel) • Trains/Steamboats/Telegraph
1798) • Communication
- End of Modern Israel) • WWW
1989) • Communication

Our Alpha History

We then began to compare and contrast. This is mostly revision/review, but we did include this 25-year time period of the dying down of persecution. Here in 1773, it's the abolishment of the Jesuit Order, and it starts to give people the freedom they need to enable this process. The Civil Rights Act did the same. Persecution arises again in Millerite history before 1850; persecution arises again in our history before the Sunday Law. But you can see that this has all to do with equality, which is why it did here in 1964 and it will here before and through the history of the Sunday Law.

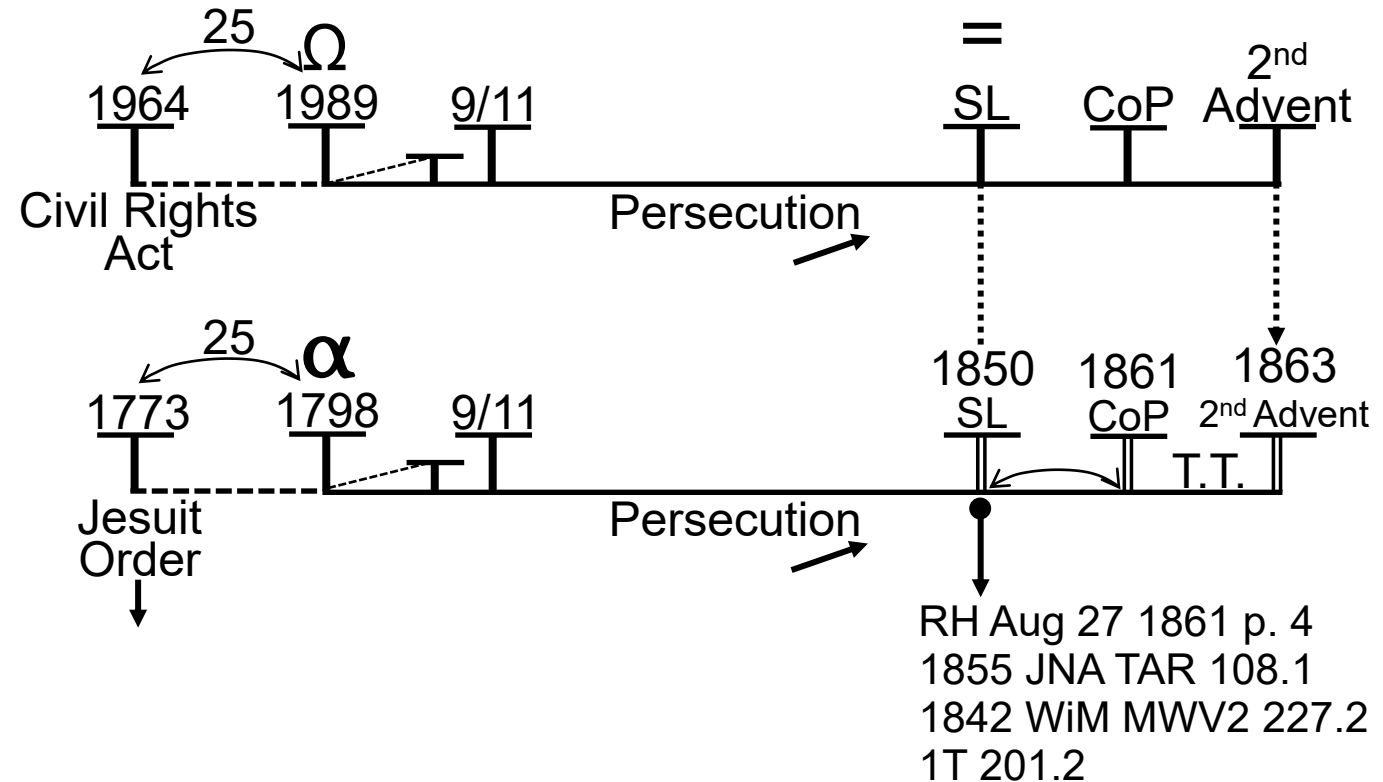

Our Alpha History

We then looked at 1850 as a waymark and reminded us of the 1850 compromise and how it caused people to be confronted with a choice: you either trample the laws of God, obeying the laws of the land, or you disobey the law of the land and uphold the law of God, which is exactly what you would expect of the test at that waymark.

Next presentation we will build the structure, the fractals of our Alpha history and begin a look at external events.

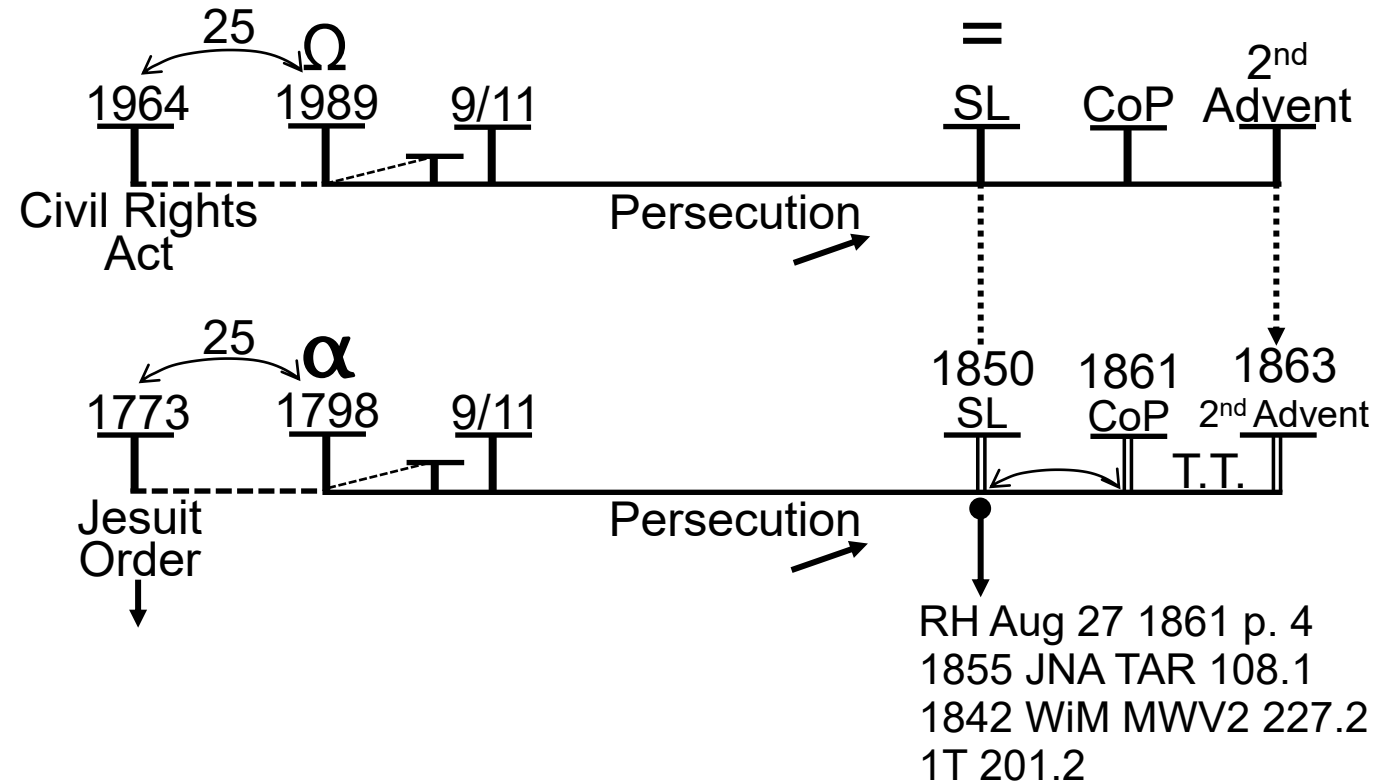

Closing Prayer

If you kneel with me, we'll close in prayer. Dear God in Heaven, thank you for our blessings. Thank you for how you have led in our past history, not just in the one that we have now, but in the past history that extends over the last six thousand years. We see Lord that while we view you as all-powerful, because you have chosen to work through humanity you are limited. You are limited by our own networks, by our own communications. If you want to work through Paul, Lord, you need to wait for there to be peace on the Roman sea and on the Roman roads. Lord you'd love the people worldwide equally, but we see how you have been limited by humanity, by your desire to work through humanity. We are grateful for your patience with us. We are thankful, Lord, for the technology that we have today, that we can speak and we can teach and we can learn together the messages that you now wish communicated worldwide. We are grateful, Lord, that this communication opens up so much of the world.



We think about countries where even YouTube is controlled. There are portions, Lord, where the light can't extend, because of their own dictatorial governments. We see how you are still limited by countries that struggle with electricity, that struggle with access to wi-fi, that struggle with governments that are repressive regimes and control the online access of their people. But still, we see you do your very best. I pray, Lord, that there might still be ways to reach these people, that they cannot be so limited in their ability to hear this gospel message. I pray, Lord, we'll learn correctly the message of selflessness, that the Midnight Cry is designed to create in us; that we consider those outside of ourselves, the needs of those outside of ourselves, the civil rights of those outside of ourselves. I pray, Lord, that we will understand the nature of your kingdom and why it is exclusive, why there are rules about who can enter and who cannot. May we see your love in these rules. May we see what they are designed to teach us and the healing that they are designed to create in us. I pray this in Jesus' name. Amen.

